



**Savannah River  
National Laboratory®**

We put science to work.™

# The Fusion Fuel Cycle and Blanket

Dave Babineau, Brenda Garcia-Diaz, Jim Klein, George Larsen, Dale Hitchcock, Chris Dandeneau  
Savannah River National Laboratory

6/18/2024

SRNL-MS-2024-00306

# “Hydrogen”: Protium, Deuterium, and Tritium

- Protium – normal “hydrogen”
- Deuterium – “heavy hydrogen” ~ 130-160 ppm natural abundance
- Tritium – a radioactive isotope of hydrogen
  - Decays to He-3 (beta decay)
  - 12.3232 years half-life
  - decay constant =  $-\ln(1/2) / t_{1/2} = 0.056247$  per year
  - $T/T_0 = e^{-0.056247 \cdot t(\text{yrs})}$ : 1 year loss  $\rightarrow 0.054695$  (5.5%)
  - T replacement @ 12.32 years =  $12.32 \cdot 0.054695 = 0.674$  ( $> 0.500$ )
  - A key component of nuclear weapons
  - Other uses
    - Self-powered lighting – watches, exit signs, night sights
    - Analytical chemistry – radiolabeling
    - Nuclear batteries (“betavoltaics”)
    - **Fuel for DT fusion (magnetic, inertial, ...)**
- Total Hydrogen Isotopes:  $Q = H+D+T$ ,  $Q_2 = H_2 + HD + D_2 + HT + DT + T_2$

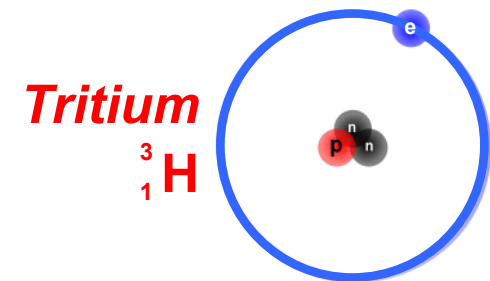
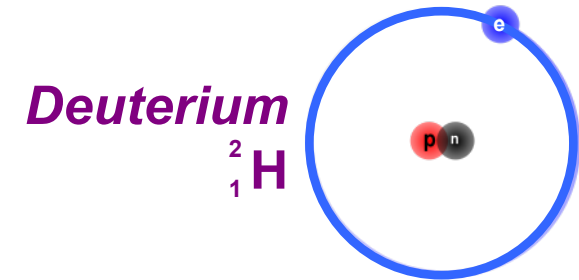
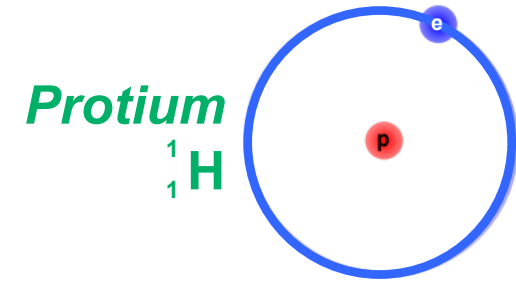

# Tritium Production

---

- Some tritium continuously produced in upper atmosphere (small amounts)

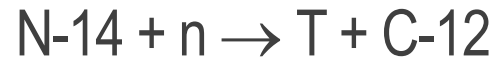

- Tritium is a byproduct from neutron capture in heavy water moderator (e.g. CANDU reactors)

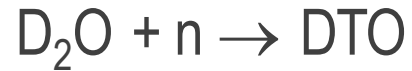

- Elemental tritium is produced by multi-step processing of heavy water (fusion T<sub>2</sub> source)



- Tritium is also produced by neutron irradiation of lithium-6 (fusion T<sub>2</sub> breeding)



# Fusion and Breeding Blanket Reactions

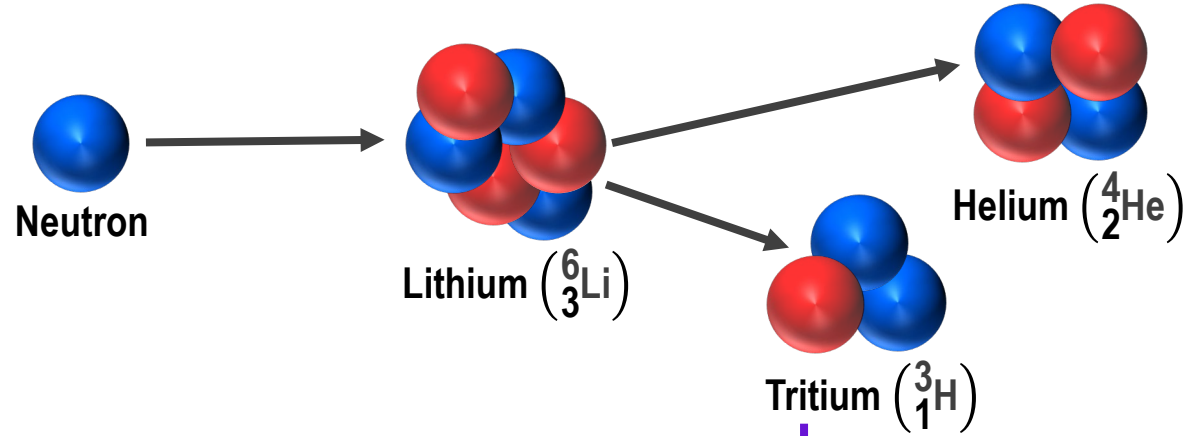
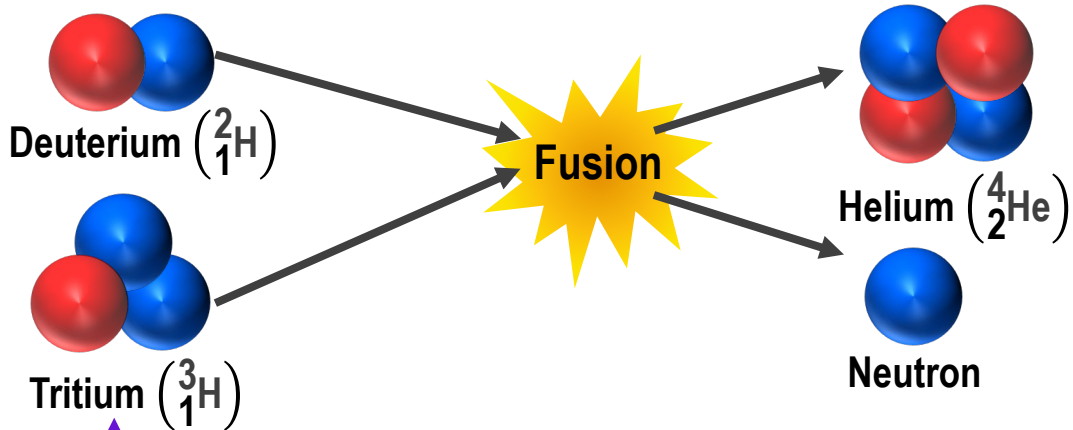
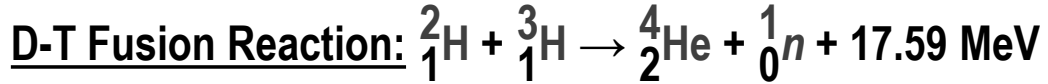

**T recovered and fed back as fuel**

D-T Fusion is the lowest temperature fusion reaction with the highest potential yield

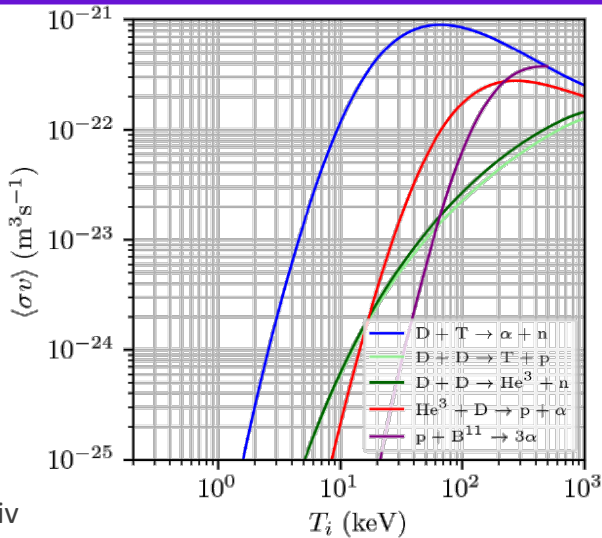

Hsu and Wurzel, 2022, arXiv

Tritium (T) breeding materials and their configurations must satisfy key criteria

- 1) Maintain a T breeding ratio (TBR) greater than 1 (account for losses)
- 2) Absorb fusion power, make it available for conversion
- 3) **Allow T to be continuously recovered**

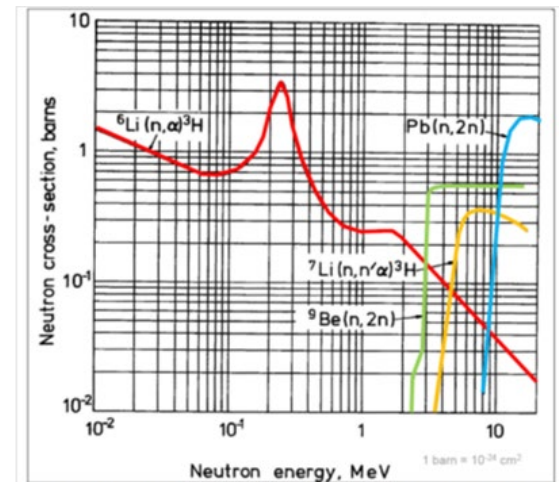

Courtesy of the National Physical Laboratory (NPL)

# Fusion and Blanket Process Flow Diagrams

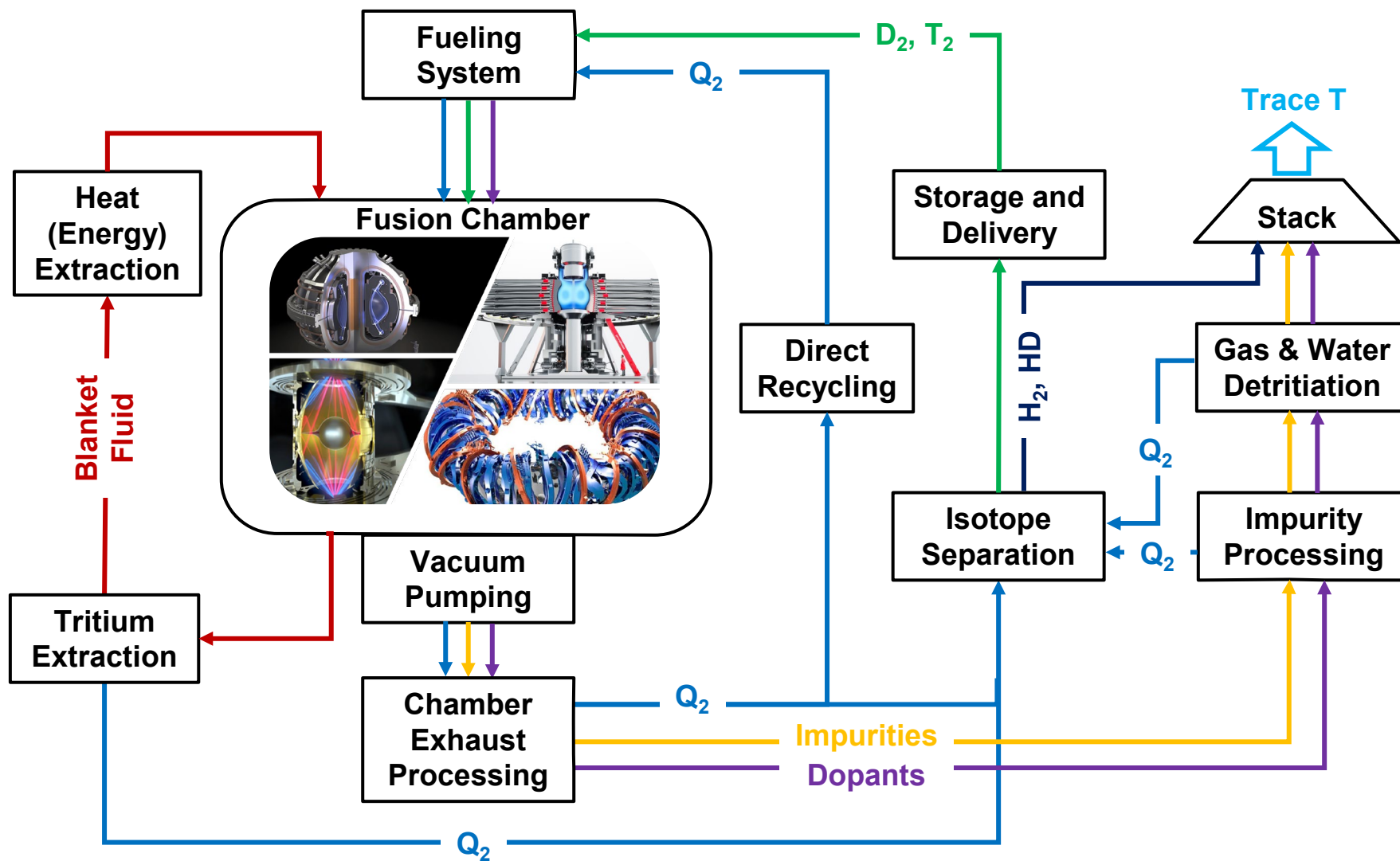

# Fusion Devices – Examples of Different Approaches



Tokamak

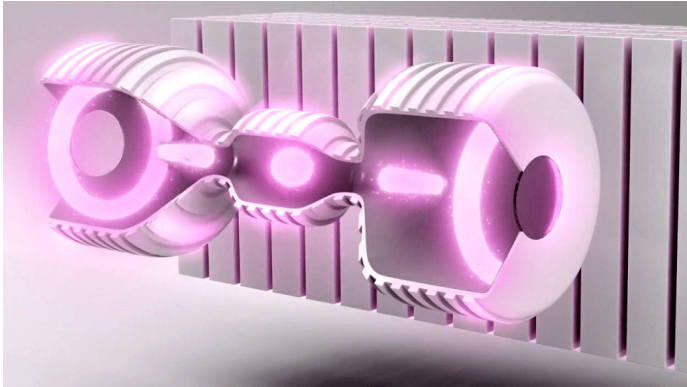

Reversed Field Pinch

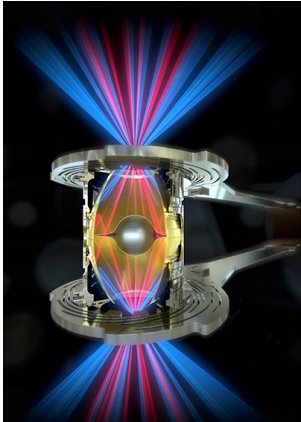

Indirect Drive Inertial Confinement

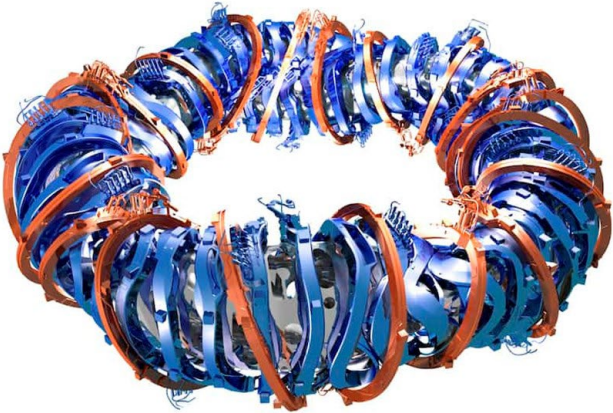

Stellarator



Z Pinch

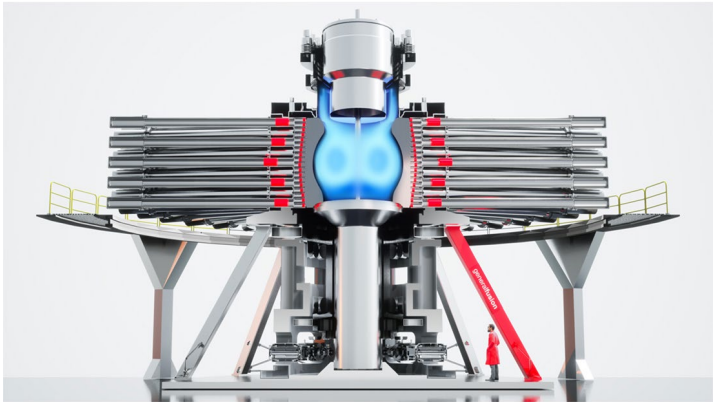

Magnetized Target

# Inertial Fusion Energy (IFE) Tritium Fuel Cycle Development

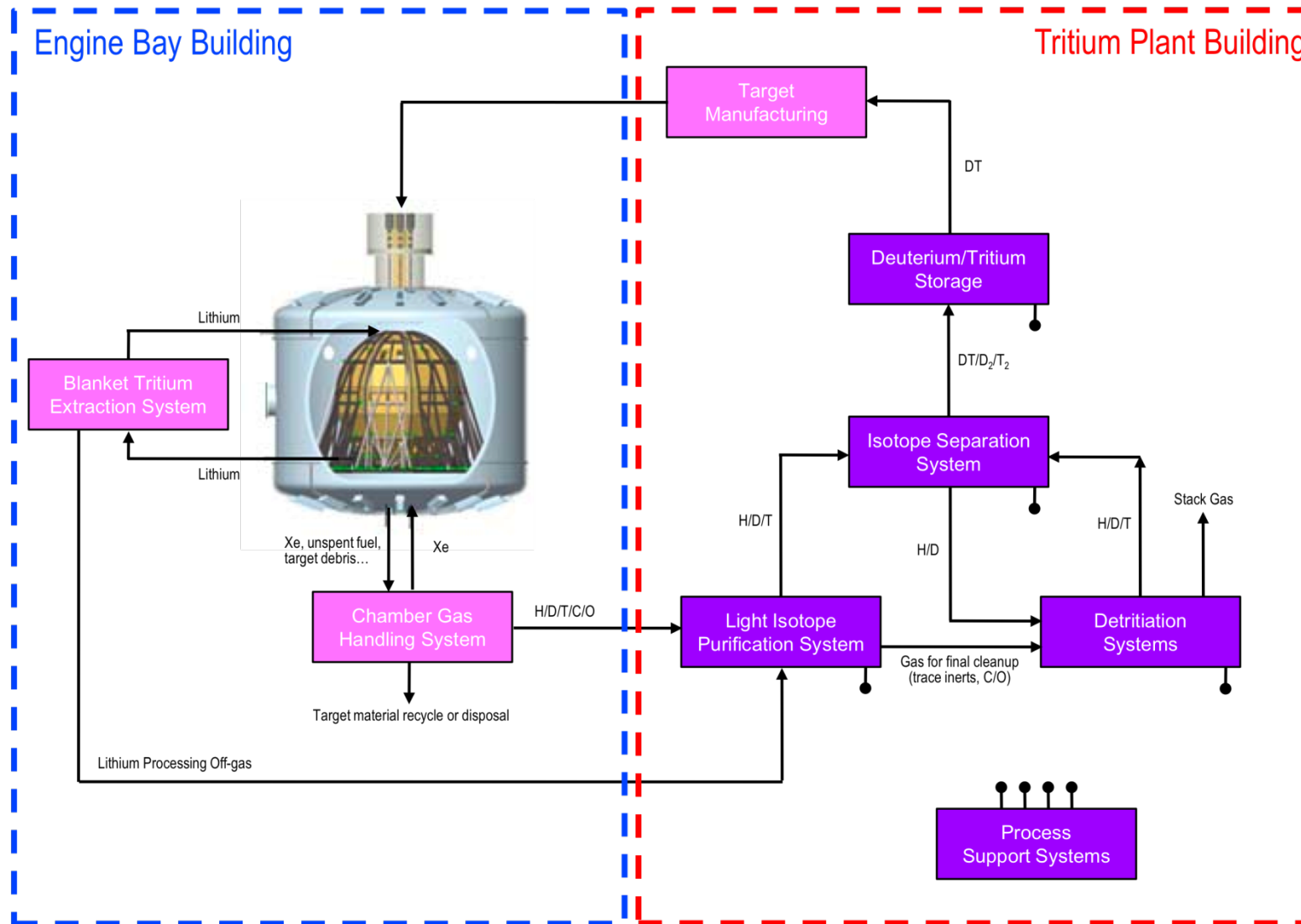

# Deuterium Tritium Fuel Cycle Flow Rate

ITER Flow  $\sim 220 \text{ Pa}\cdot\text{m}^3/\text{sec} = ???$

[Units of  $P\cdot V$  per time]

$1 \text{ Pa}\cdot\text{m}^3/\text{sec}$

$$= 1 \text{ Pa}\cdot\text{m}^3/\text{sec} \cdot 1000 \text{ L}/\text{m}^3 \cdot 60 \text{ sec}/\text{min} \cdot 760 \text{ torr}/1.01325 \times 10^5 \text{ Pa}$$

$$= 450 \text{ torr}\cdot\text{L}/\text{min}$$

Ideal Gas Law:  $V_s \cdot P_s = V \cdot P$ , or  $V_s = V \cdot P / P_s$

$$V_s = (V \cdot P) / P_s$$

$$= (450 \text{ torr}\cdot\text{L}/\text{min}) / (P_s = 760 \text{ torr}) = 0.5922 \text{ SLPM per } 1 \text{ Pa}\cdot\text{m}^3/\text{sec}$$

$$V_s = 220 \text{ Pa}\cdot\text{m}^3/\text{sec} * 0.5922 = \underline{130 \text{ SLPM}} \text{ (Standard Liters per Minute)}$$





# Tritium Storage: Metal Hydride Technology and Thermal Swing Operation

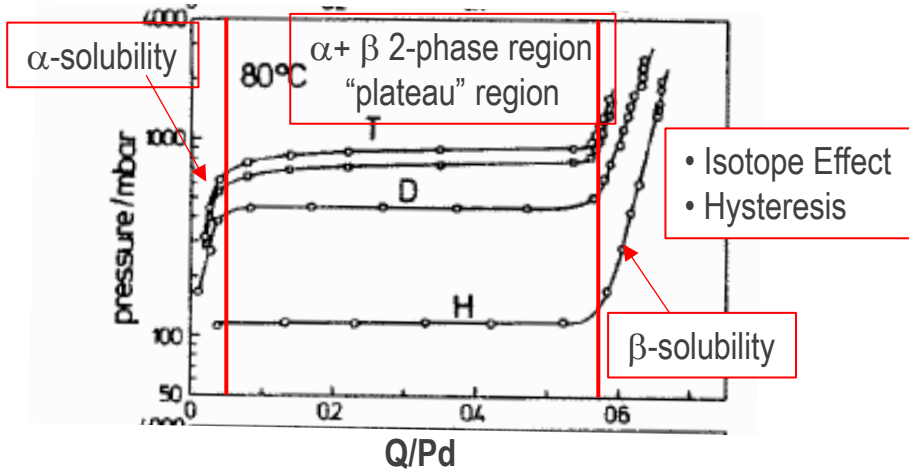

Palladium – Q (H, D, T) Isotherms  
PCT: Pressure, Composition, Temperature

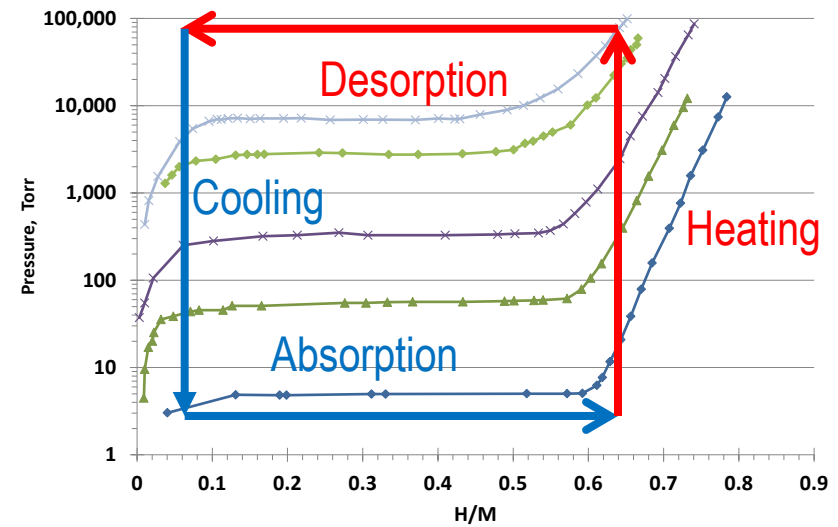

Hydride (Pd) Thermal Cycling

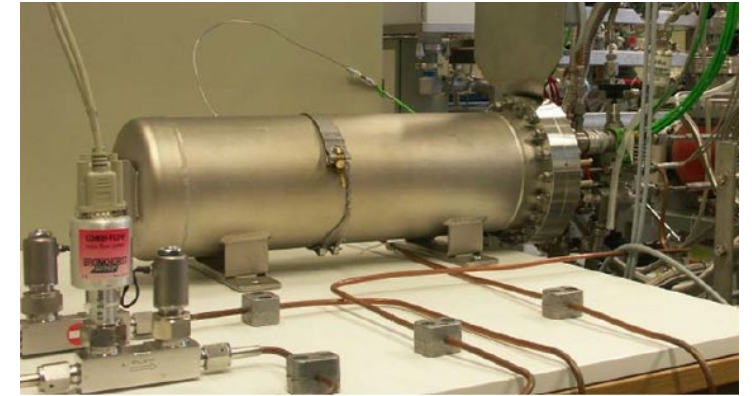
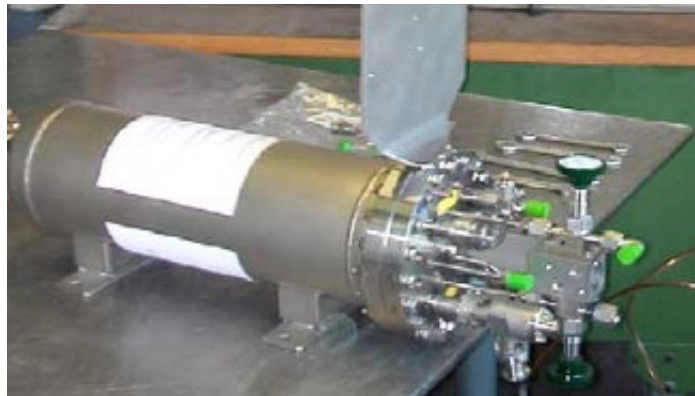
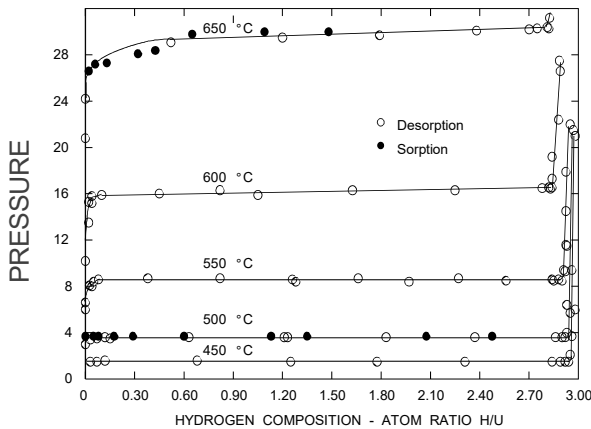

# Tritium Storage – Metal Hydride Technology

- Hydride Bed Design Considerations (some)
  - Required operating pressure range (hydride determines operating temperature range/swing)
  - Required working inventory/capacity
  - Cycle Time and Rates: Heat Up, Desorption, Cool Down, and Absorption
  - Wall stresses (hydride formation increases volume)
  - Tritium inventory measurements: process and disposal

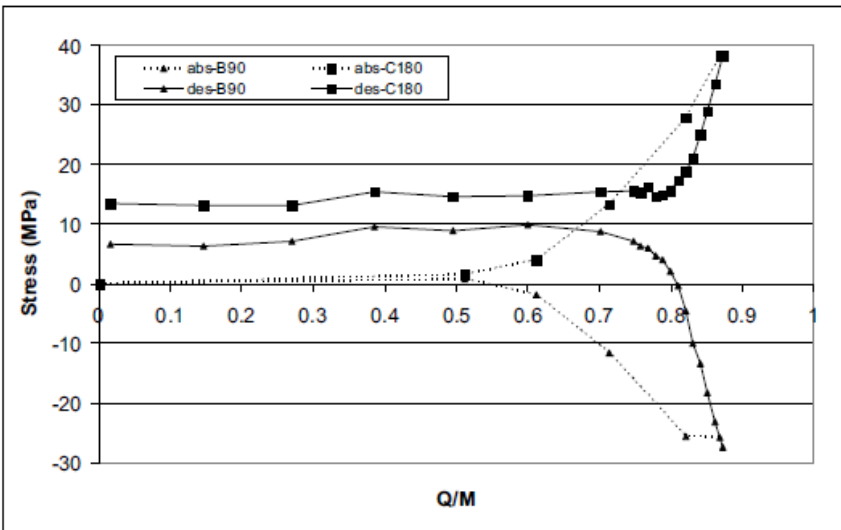

Bed Wall Stress: 2005 Estochen, Klein

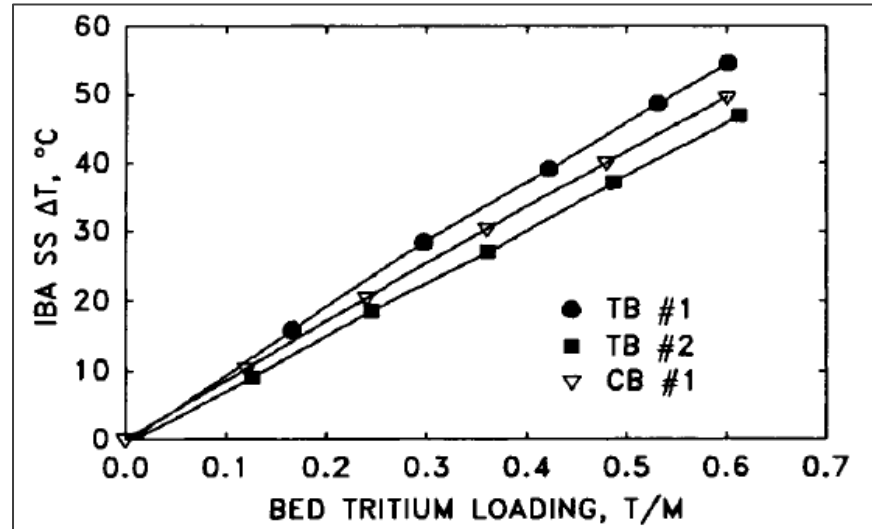

Tritium In-Bed Inventory: 1995 Klein

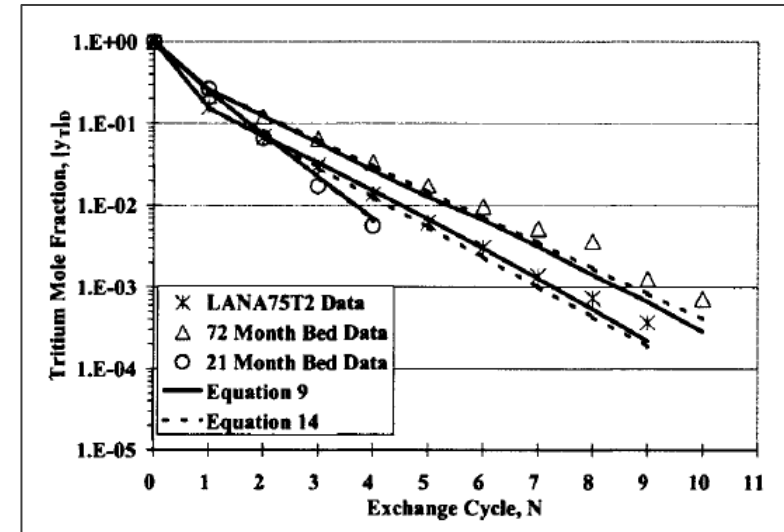

Isotopic Exchange: 2002 Klein, Wermer



# Tritium effects on materials-hard materials

- Increased tritium retention in some storage materials

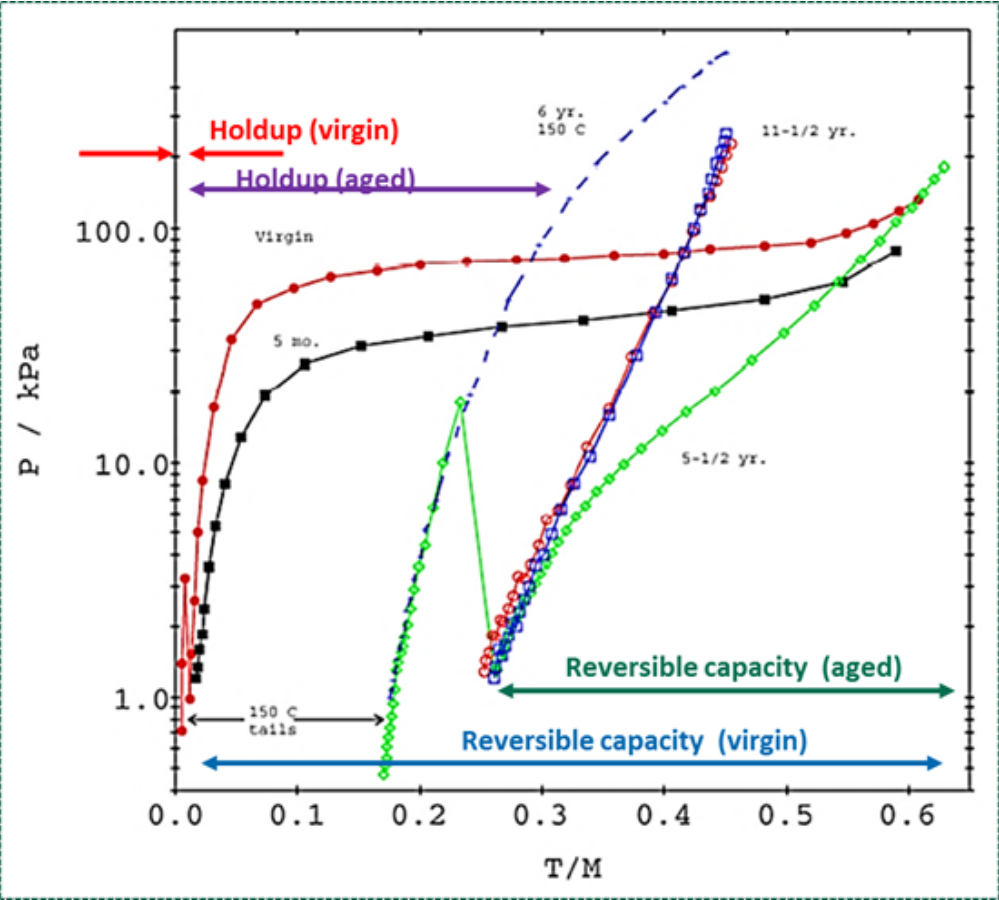

# Tritium effects on materials-hard materials

- Fracture toughness of austenitic stainless steels is degraded by tritium Further reduced by born-in helium
- Hydrogen/Tritium diffuse into steel, Tritium decays to helium
- Evolution of Helium bubbles degrades mechanical performance as component ages

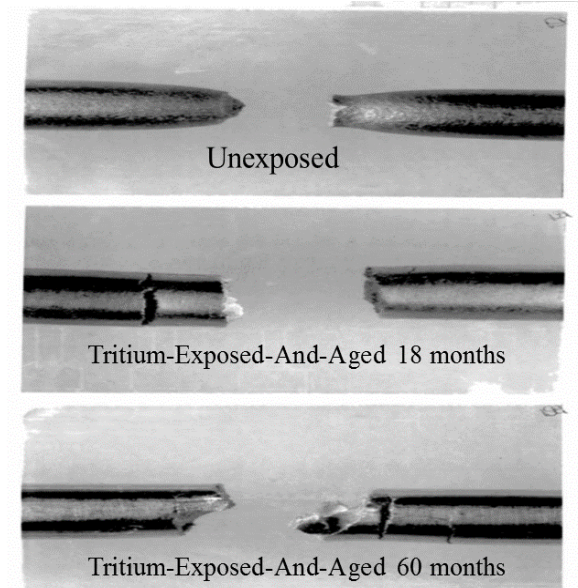
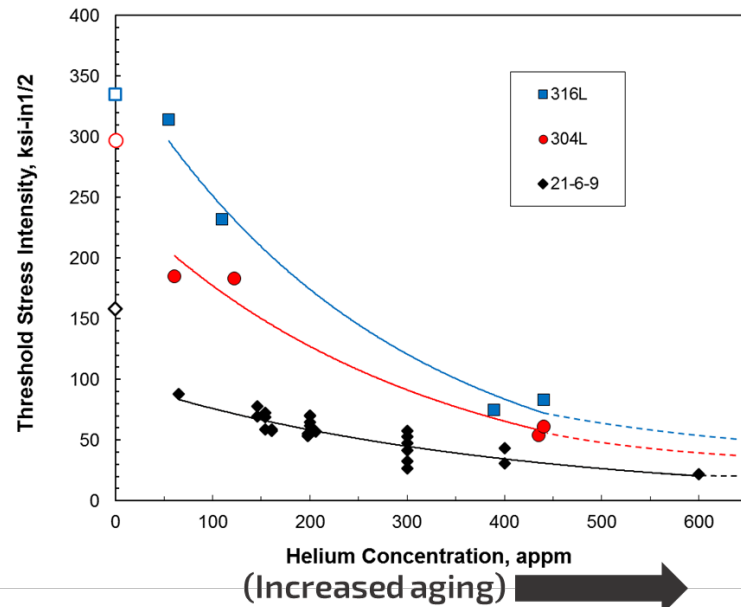
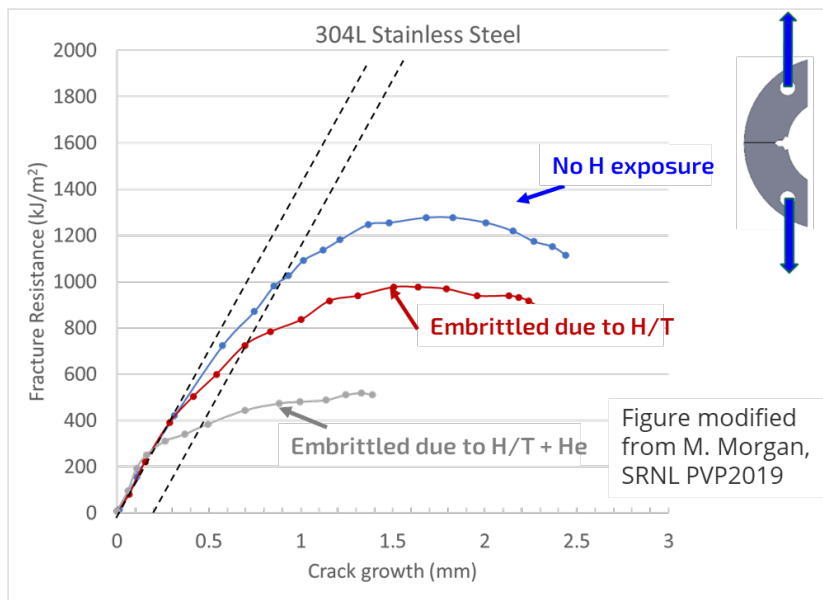

Source: SRL Notebook  
Dave Rawl, 11/7/79



# Deuterium Tritium Fuel Cycle: Fueling (Pellet Injection, Gas Puffing)

- Fuel cycle exists because:
  - Fusion burnup is low
  - Tritium is rare
- Challenging because:
  - Tritium is radioactive
  - Behaves like hydrogen
- Fuel cycle is similar between different fusion approaches
  - But minor differences may have large impacts on scale and technologies

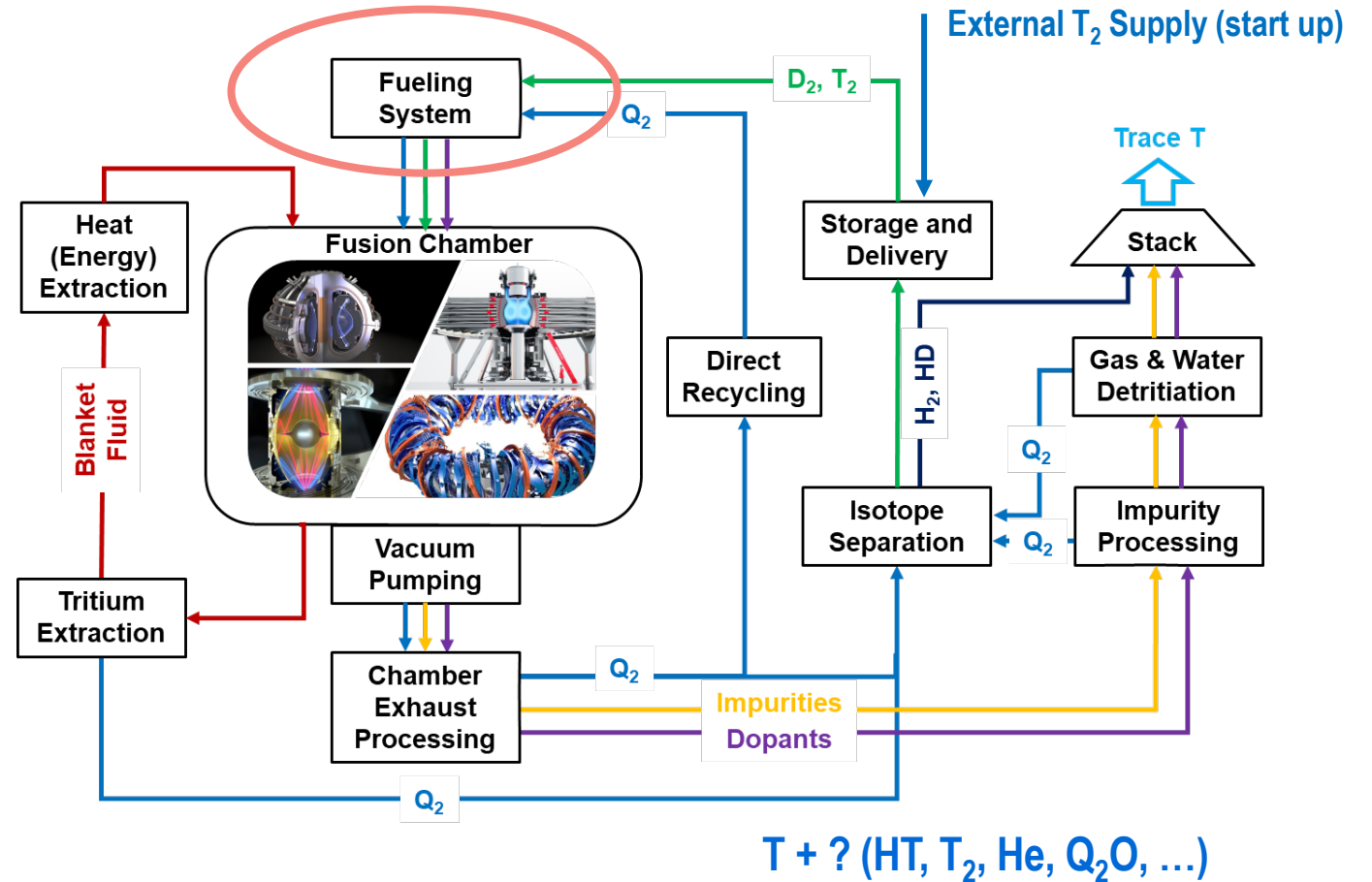

*Goal: Supply chamber with DT fuel within specifications, while minimizing emissions*



# Fueling – Pellet Injection (2007, Baylor, et. al)

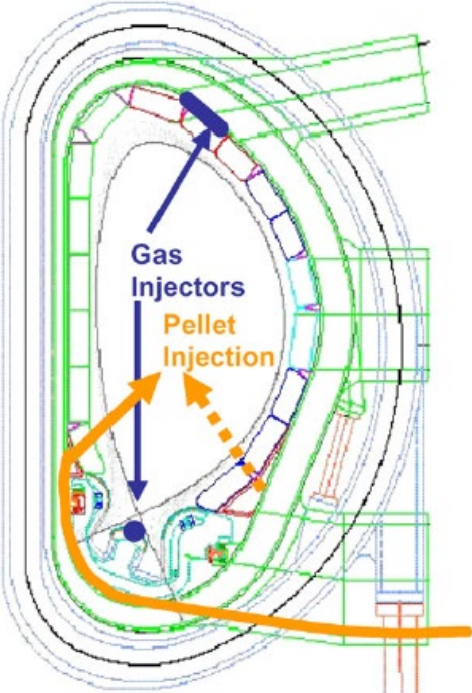

Figure 1. Cross section of ITER showing the pellet injection and gas injection locations. The dashed pellet trajectory is the proposed low field side location for ELM triggering.

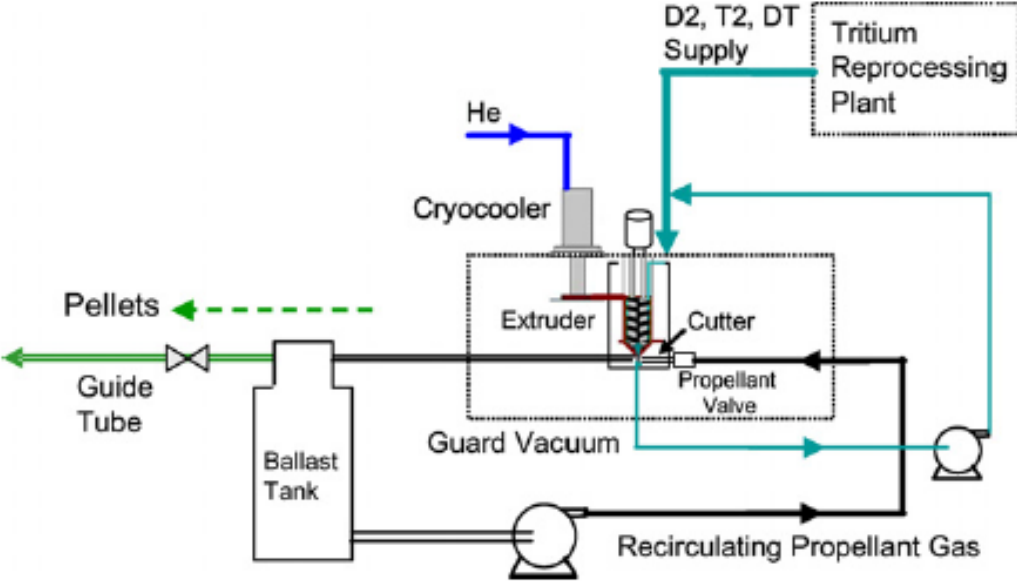
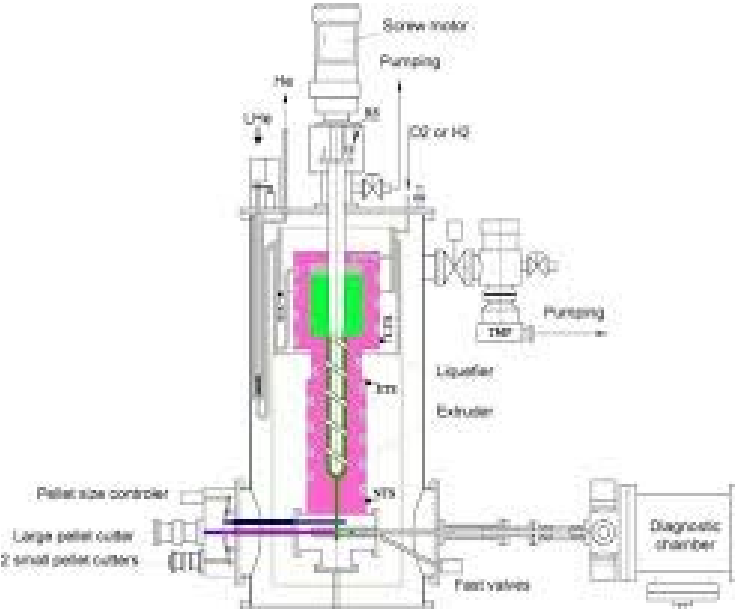
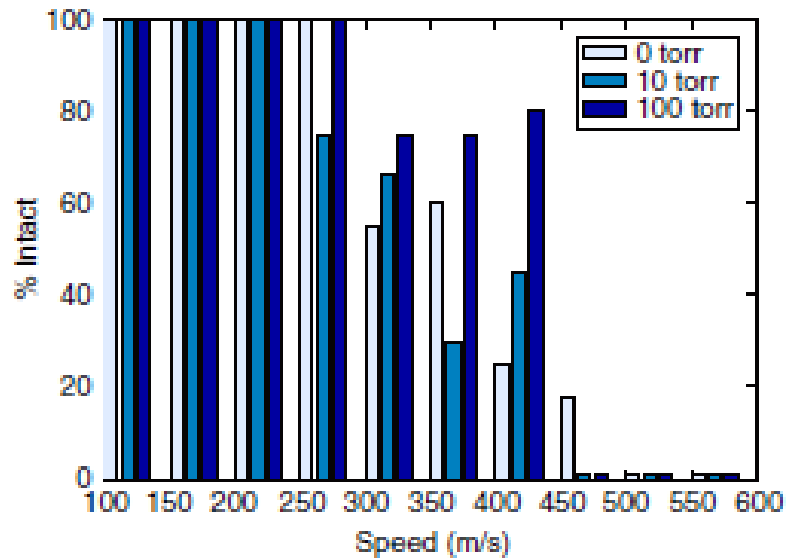

Figure 3. Block diagram of the proposed gas gun pellet injection system for ITER.



# Fueling – Pellet Injection (continued)



**Figure 2.** Guide tube test results showing the per cent of intact pellets at different speed ranges for the inner wall guide tube mockup. Tests were performed at 3 different pressures in the guide tube.

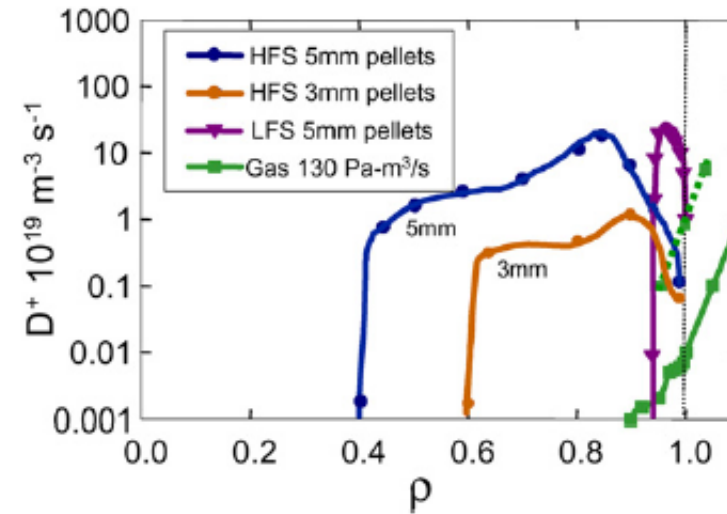
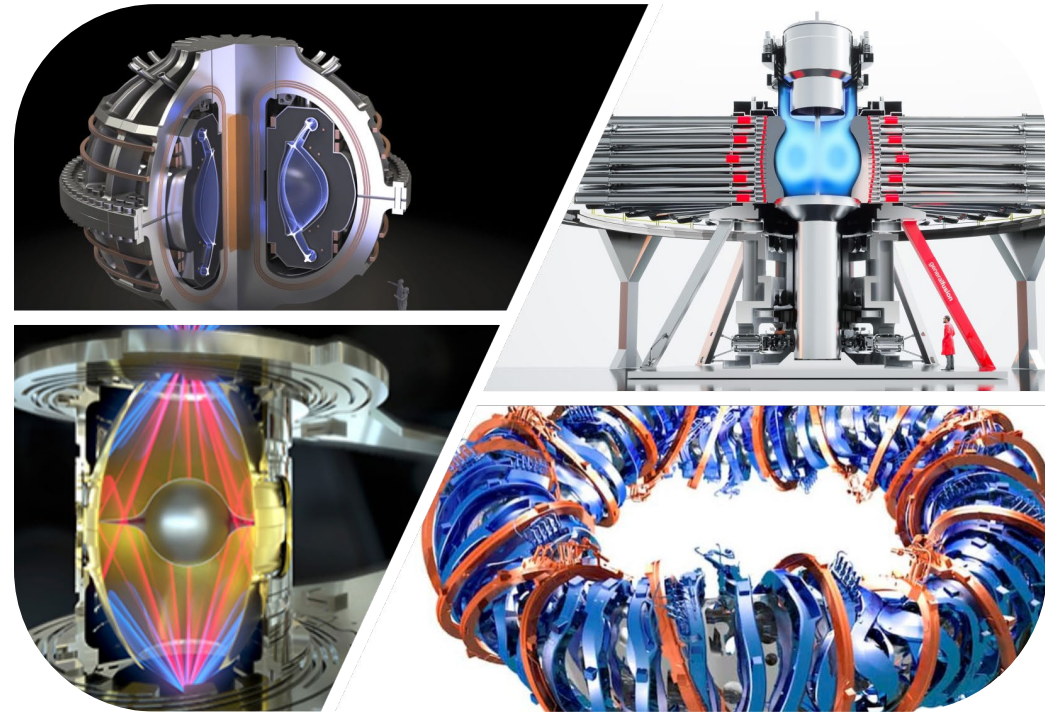

**Figure 4.** Comparison of pellet fuelling and gas fuelling source profiles for ITER using the specified 16 Hz 5 mm pellets and 130 Pa m<sup>3</sup> s<sup>-1</sup> (1000 TorrL s<sup>-1</sup>) of gas. The dashed gas curve is calculated from the SOLPS code in actual ITER geometry. The solid gas curve is from a B2-Eirene slab calculation.



# Fusion Chamber

- Fusion Chamber (e.g., Tokamak, Stellarator, IFE ) Tritium Hold-Up
  - Not all tritium introduced comes out
  - Surface hold-up
  - Diffusion into/through metals
  - Co-deposit on walls
- Fusion Chamber Tritium recovery
  - Heated desorption
  - He/D<sub>2</sub> Glow Discharge (plasma) cleaning
  - Disassembly and Processing
    - Heated evacuation in Hot Cell Facility



# Deuterium Tritium Fuel Cycle: Vacuum Pumps

- Fuel cycle exists because:
  - Fusion burnup is low
  - Tritium is rare
- Challenging because:
  - Tritium is radioactive
  - Behaves like hydrogen
- Fuel cycle is similar between different fusion approaches
  - But minor differences may have large impacts on scale and technologies

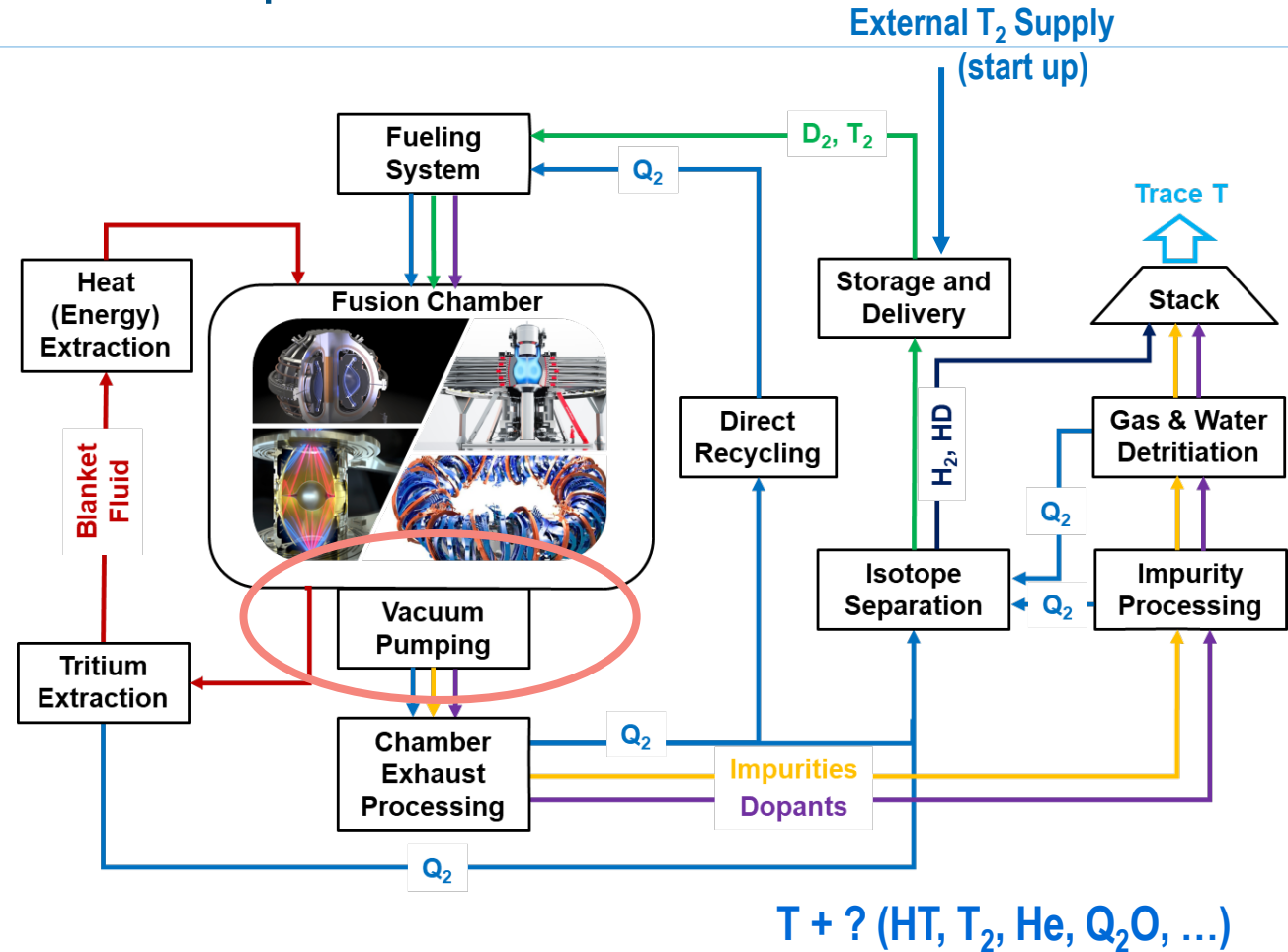

*Goal: Supply chamber with DT fuel within specifications, while minimizing emissions*



# Vacuum Pumping

- Molecules move from higher density to lower density
- Vacuum pumps used to decrease gas pressure at pump inlet (thus process pressure)
- Most vacuum pumps increase gas pressure (“Compression Ratio“)
- Different pumping technologies depending on operating pressure

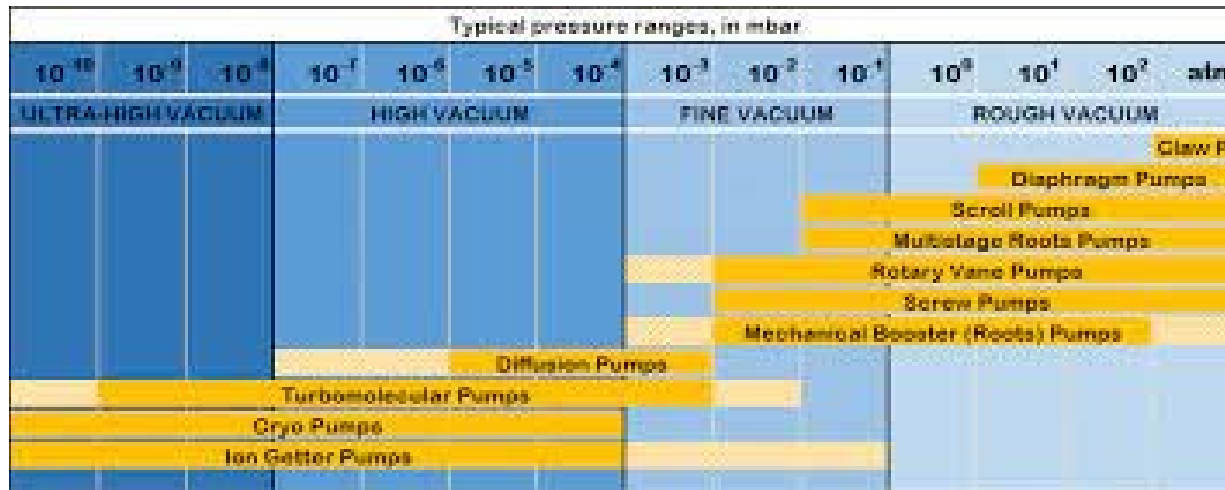

(Google Images: Leybold)

# ITER Pumping Solution – Liquid Helium Cryopumps

- Helium-cooled charcoal-coated fins condense  $D_2$  and  $T_2$  from the torus – removes gas molecules from process stream
- Inefficient (low discharge pressure), but works - every molecule of hydrogen must be cooled to 4.5 K
  - Nearly 15% of the energy from fusion power will go into vacuum pumping!<sup>1</sup>
- Cryopumps scaling is challenging – ITER requires the largest cryopumps ever made.

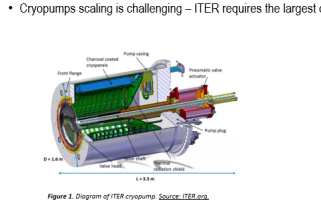

Savannah River National Laboratory

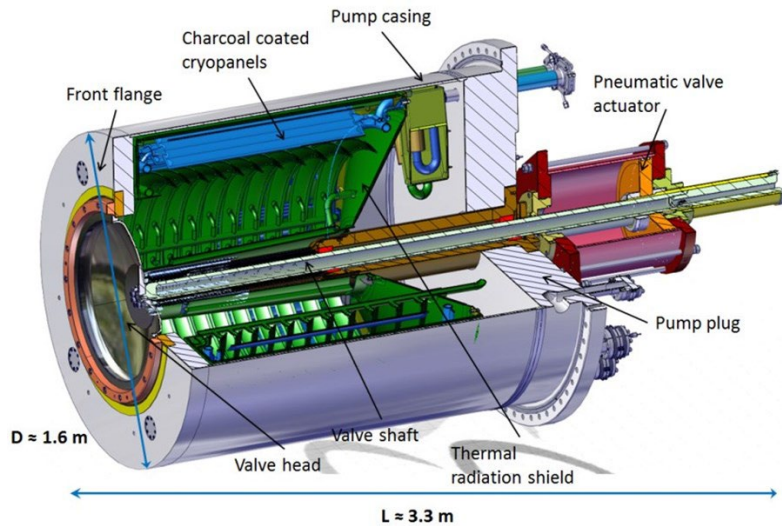

Figure 1. Diagram of ITER cryopump. Source: ITER.org.



Figure 2. Photograph of ITER cryopump. Source: ITER.org.

# Alternative Solutions: Diffusion and Metal Foil Pumps

## Diffusion Pumps



Source: EdwardsVacuum.com

## Mercury

## Radiation Resistant Oil

### • Pros:

- Historically proven at smaller scales
- Tritium compatibility
- Potentially scalable to required fluxes

### • Cons:

- Hg is a poor vacuum fluid
- Hg is highly mobile and damaging
- Costly disposable and maintenance
  - Historical \$15k/L + \$350k/Ci
- Environmental concerns

### • Pros:

- Historically proven at smaller scales
- Tritium and radiation compatibility being addressed
- Potentially scalable to required fluxes

### • Cons:

- Radiation affects performance
- Isotope exchange occurs
- Degradation products need removal

Guin, Tyler, et al. "Organic vacuum pump fluids for the vacuum pumping of fusion power plants." *Fusion Science and Technology* (2023): 1-11.

## Metal Foil Pumps

### • Pros:

- No fluids or disposal concerns
- Inherently compatible with tritium
- Combines hydrogen separation and pumping

### • Cons:

- Low technology readiness level (TRL)
- Not a complete solution - requires other pumps

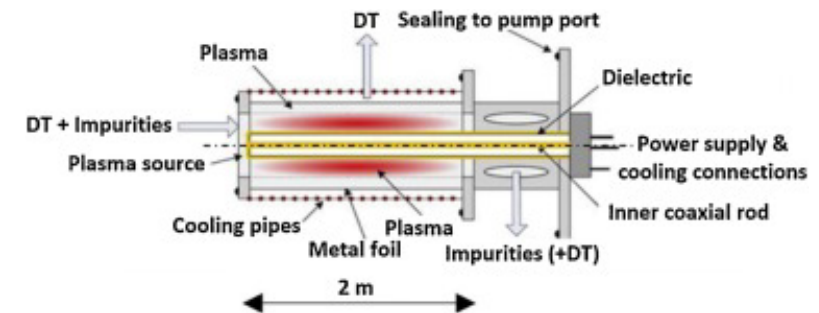

Hoffman, J., et al., *Fusion Engineering & Design*, 2020. 111890



# Alternative Solutions: Radiation Resistant Oils

- Commercial oil-based pumping technologies
  - Exist at scale, established reliability
  - Robust supply chain
  - More energy efficient than cryopumps
- Conventional wisdom - *Do not mix organics with tritium!*
  - Radiation damage, isotope exchange
  - We believe this is overly conservative
- We propose to use tritium-resistant oils and then detritiate and purify the tritiated oil

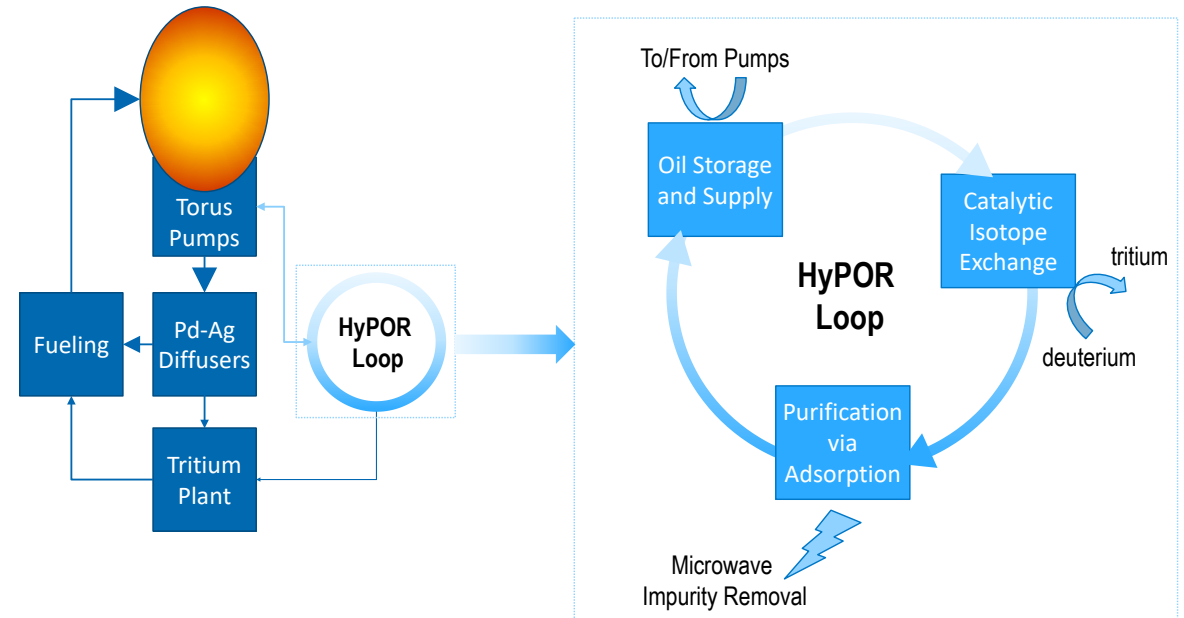

# Alternative Solutions: Radiation Resistant Oils Purification

Step 1

Direct isotope exchange

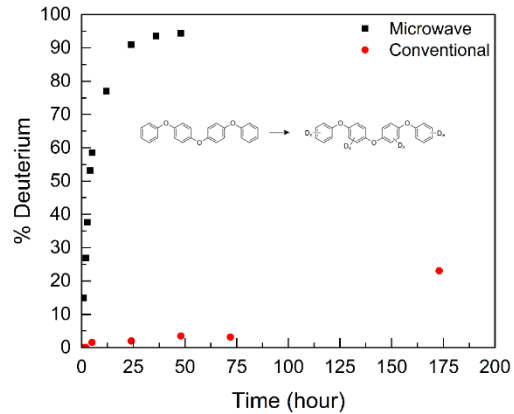
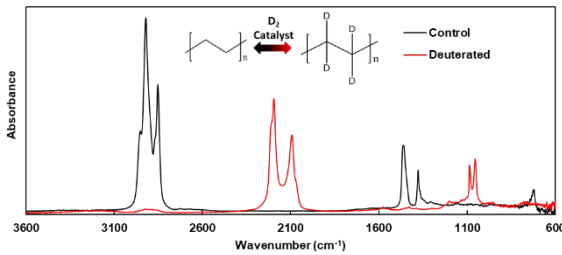

We've achieved record-breaking isotope exchange in organic molecules

Step 2

Removal of degradation products

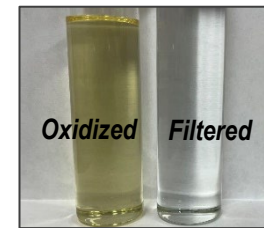
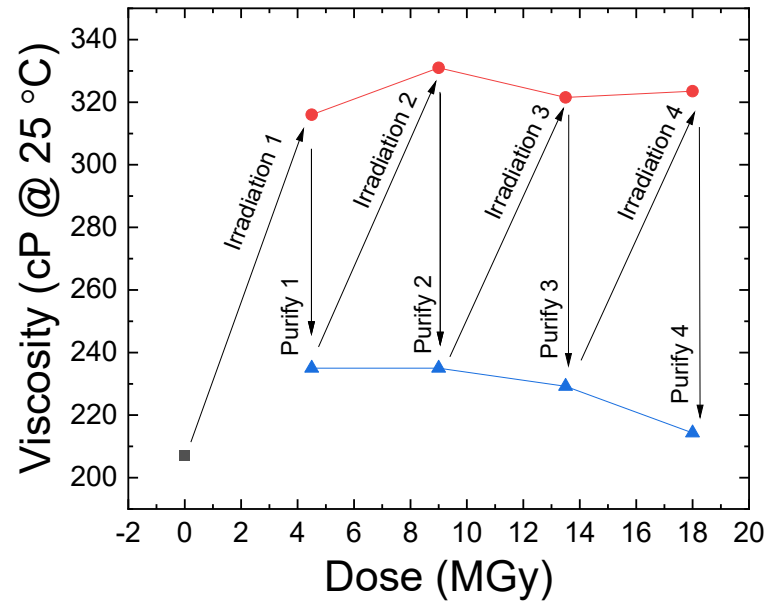

Demonstrated scalable methods to recycle oils for long lifetimes (>10 years) in high radiation and tritium

Step 3

Regeneration of sorbent/catalyst

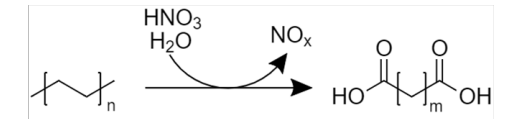

We can minimize waste and cost by regenerating our process materials

# Additional Results

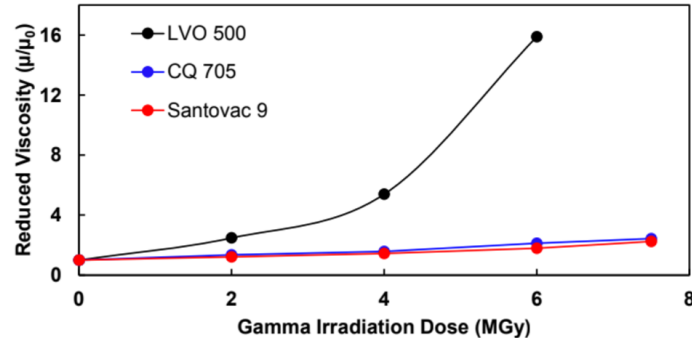
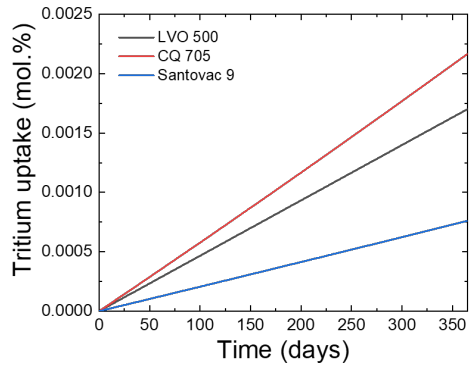
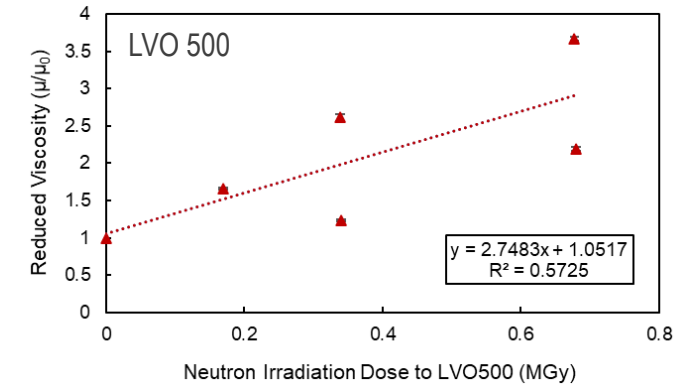
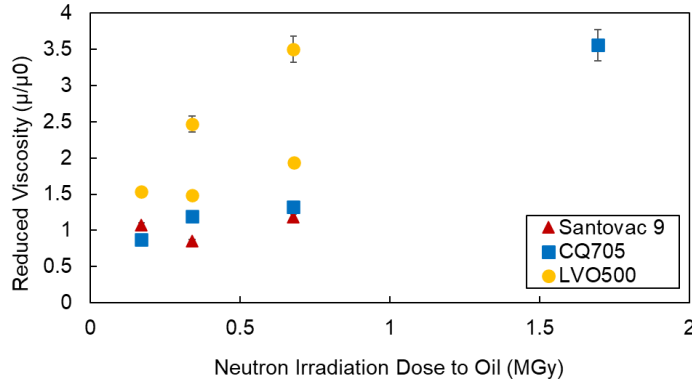
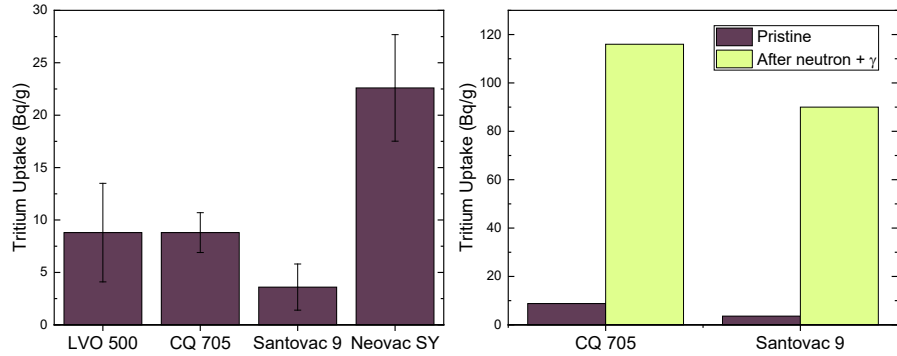

- Tritium uptake can be minimal and does not appear to be a limiting factor in the use of oils

- Radiation is the limiting factor.
- Neutrons are about 5x more damaging to oils than gamma irradiation
  - Also, expect activation from Cl

- Deuteration of oils significantly reduces their damage in neutron environments

# Tritium effects on materials-soft materials

- Generally soft materials (i.e. polymers) are not preferred for tritium service
  - Previous work suggests aromaticity may be a good predictor of tritium performance
  - More work on tritium resistant polymers is needed
  - Tritium resistant oil would be very valuable
- Aromatic polymers perform “well”  
fluorinated polymers do not

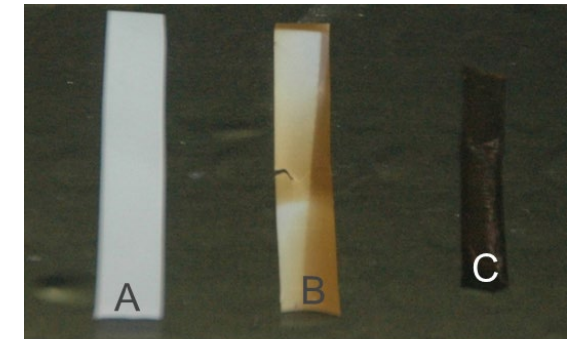
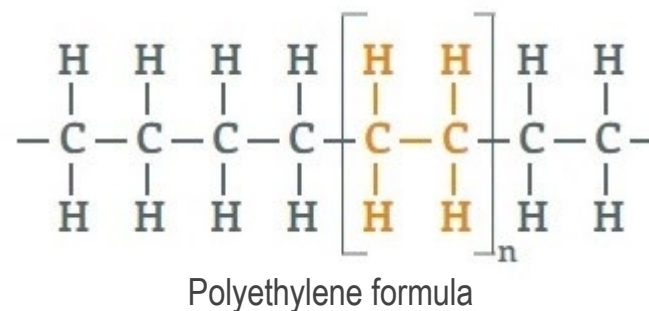
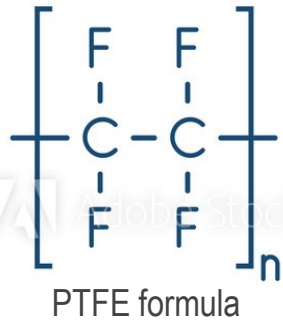
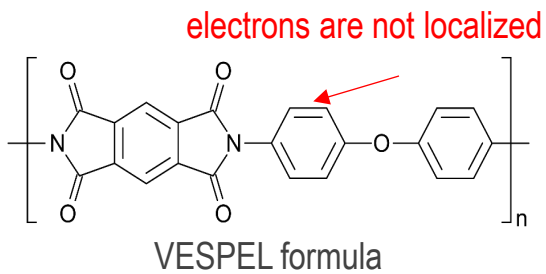
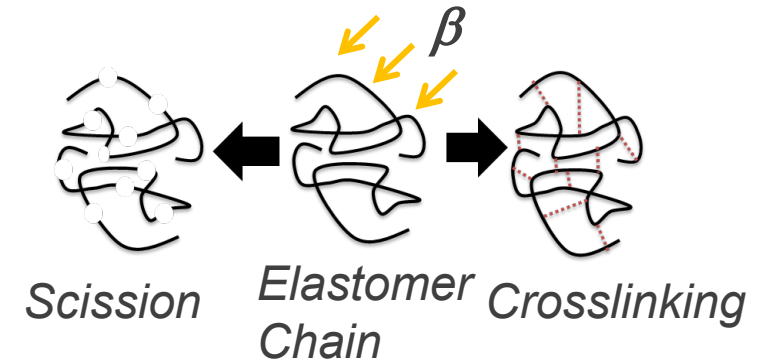

PTFE unexposed (A), PTFE exposed (B) and Nafion 117 (C) after 40 weeks of tritium exposure.

# Tritium Reactions with Soft Materials

- Polymer/tritium exposures: UHMW-PE, PTFE, and Vespel®

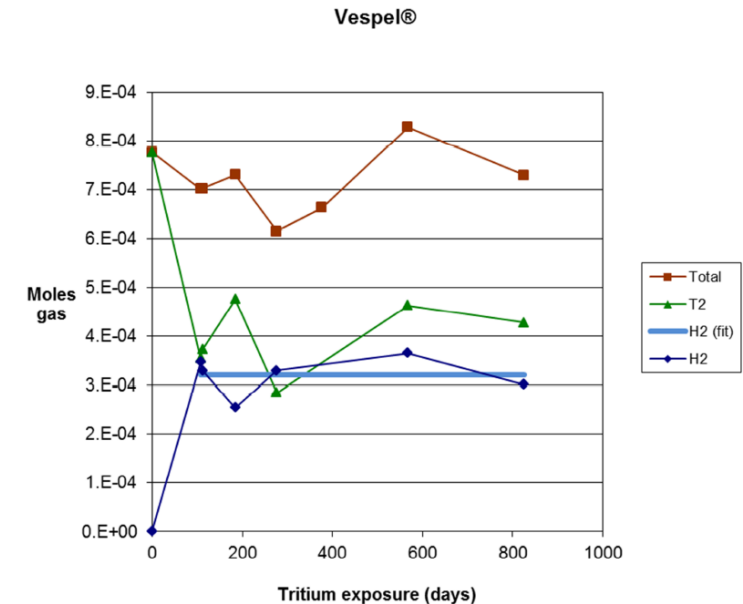
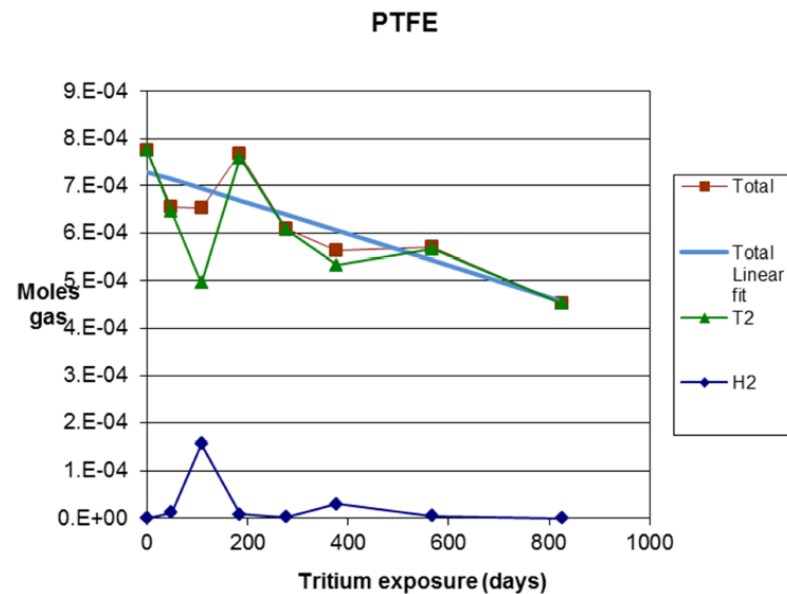
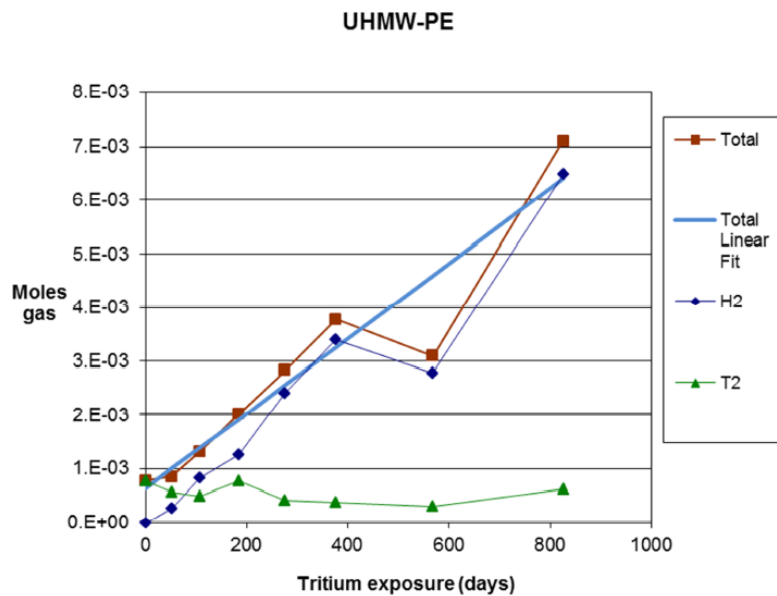

Ref. E. A. Clark, Radiolytic Gas Production Rates of Polymers Exposed to Tritium Gas, SRNL-STI-2013-00506



# Alternative Solutions: Radiation-Stable Silicone Elastomers

- Vinyl-free silicone synthesis results in elastomers with extraordinary stability in gamma radiation.
- No change in properties after 1 MGy irradiation in air.
- Phenyl silicone elastomers have superior gas barrier to conventional methyl silicones.
- Tritium testing planned.

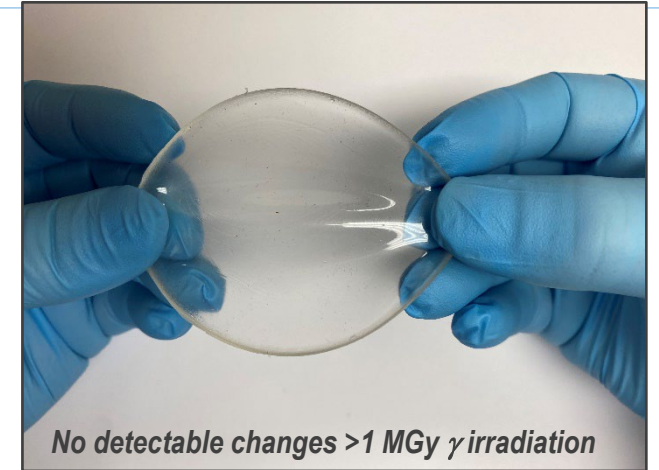
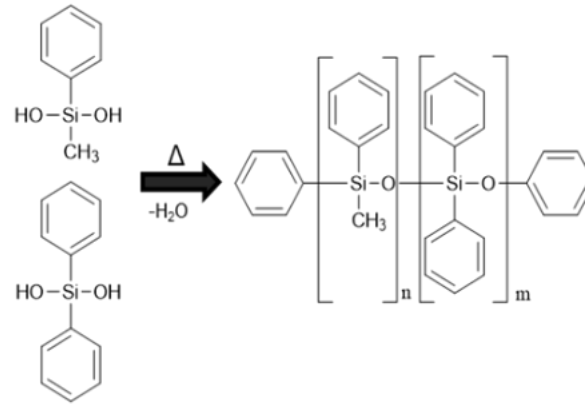

Sample	Radiation Dose (kGy)	$\Delta T_g$ (°C)	$\Delta$ % Modulus (kPa/kPa)	$\Delta$ Crosslink Density
Commercial Silicone	1000	~ +40°C	~110%	~ -100%
Butyl Rubber	100	~ +4°C	~10%	~ +50%
Literature Phenyl Silicone	1150	Unknown	~10%	~ +25%
<b>SRNL Phenyl Silicone</b>	<b>1000</b>	<b>0°C</b>	<b>~0% (within error)</b>	<b>&lt;10% (LOD)</b>

# Deuterium Tritium Fuel Cycle: Exhaust Processing and DIR

- Fuel cycle exists because:
  - Fusion burnup is low
  - Tritium is rare
- Challenging because:
  - Tritium is radioactive
  - Behaves like hydrogen
- Fuel cycle is similar between different fusion approaches
  - But minor differences may have large impacts on scale and technologies

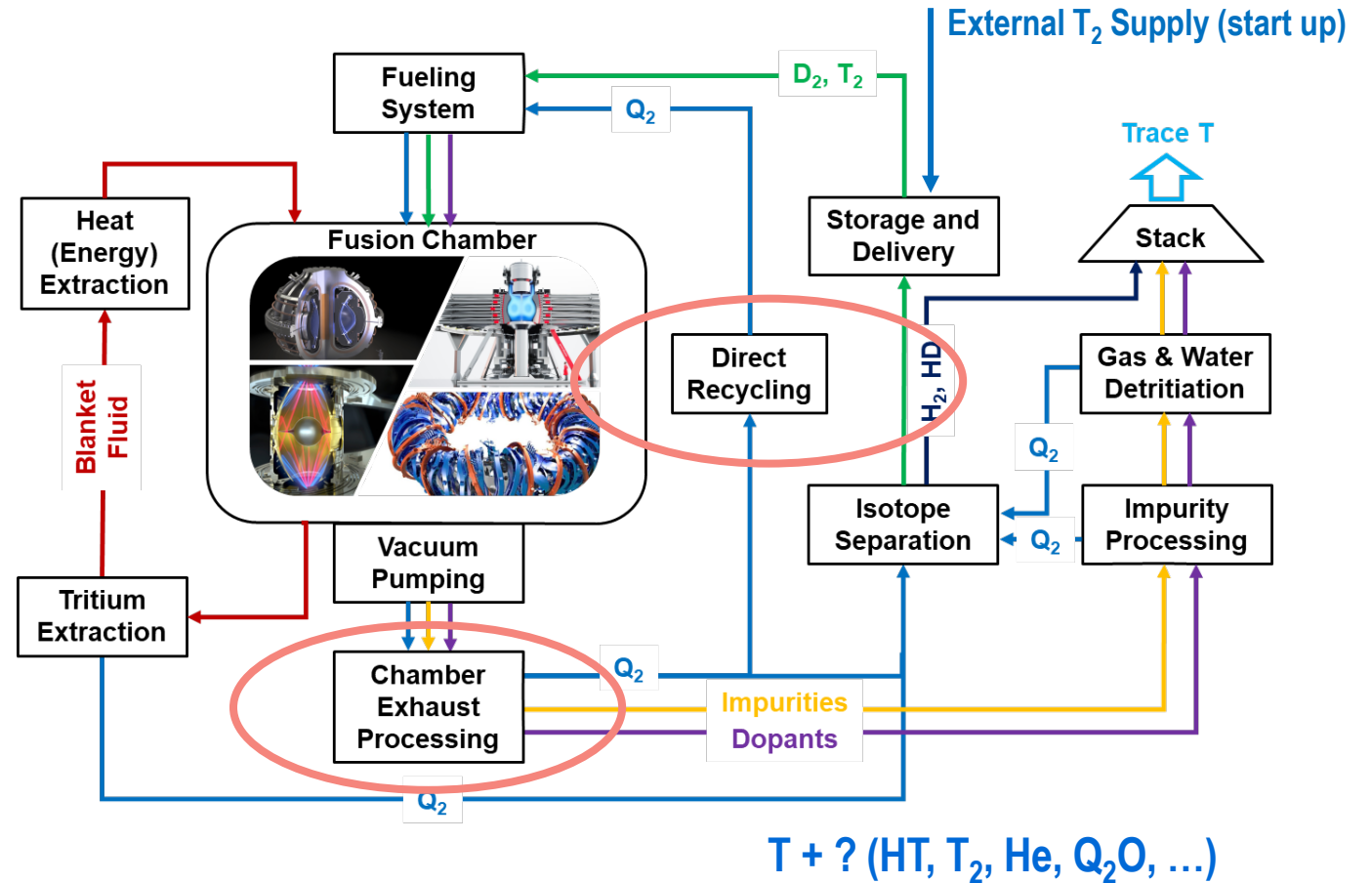

*Goal: Supply chamber with DT fuel within specifications, while minimizing emissions*

# Primary Separation - Palladium (Silver) Diffusers/Permeators

Permeate  $Q_2$ : Sent to Isotope Separation System (ISS)  
(Vacuum – Low Pressure)

Bleed/Raffinate  
(sent to Vent Detritiation System)

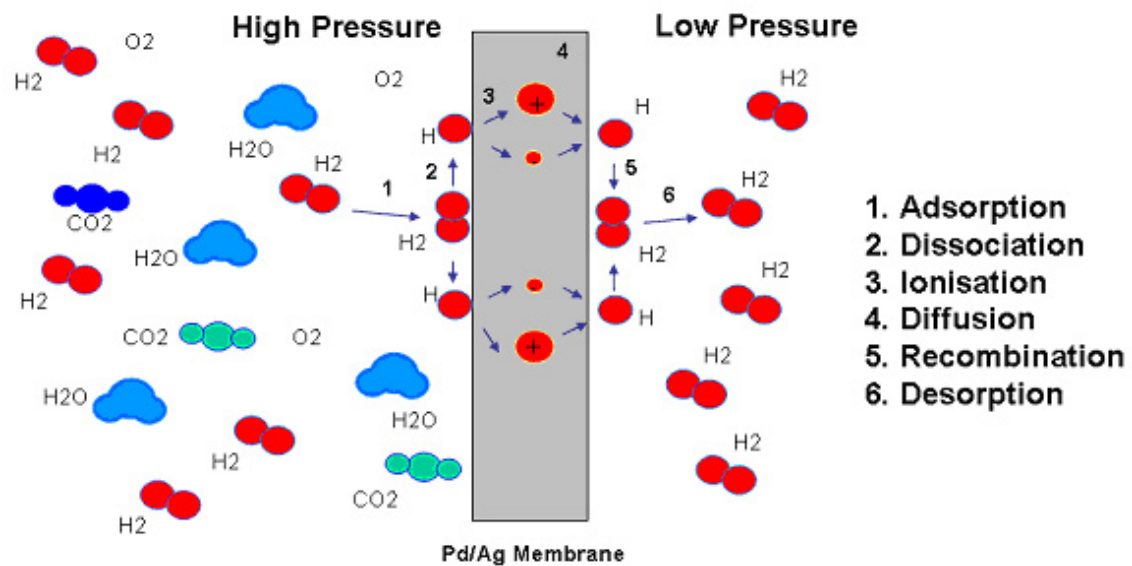
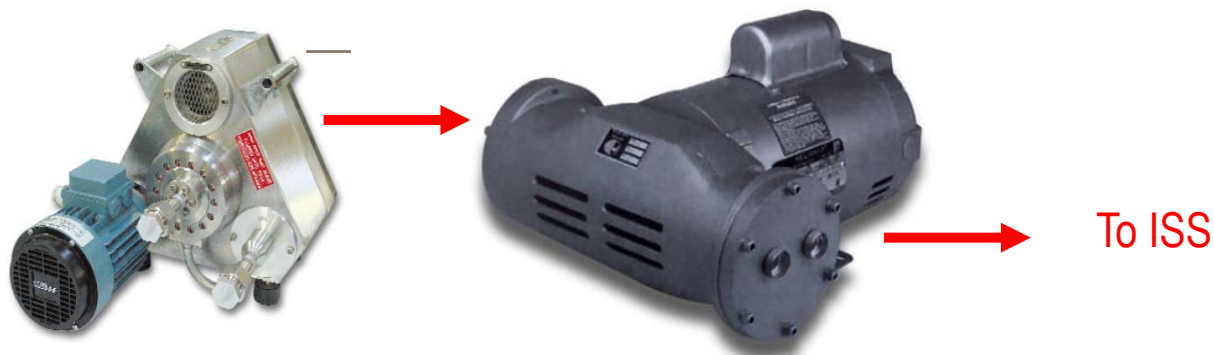
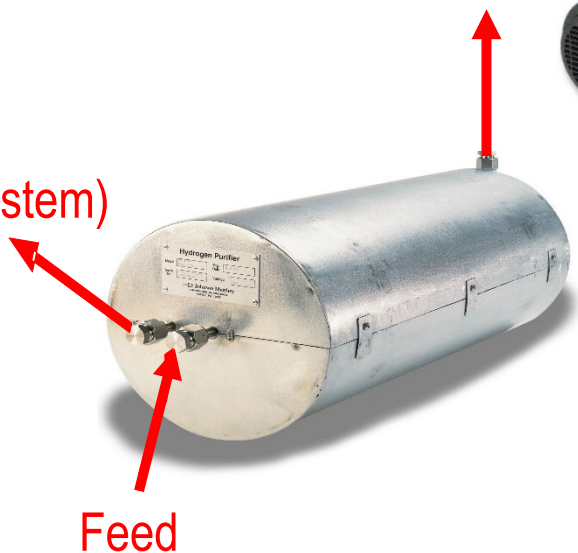

# Direct Internal Recycling

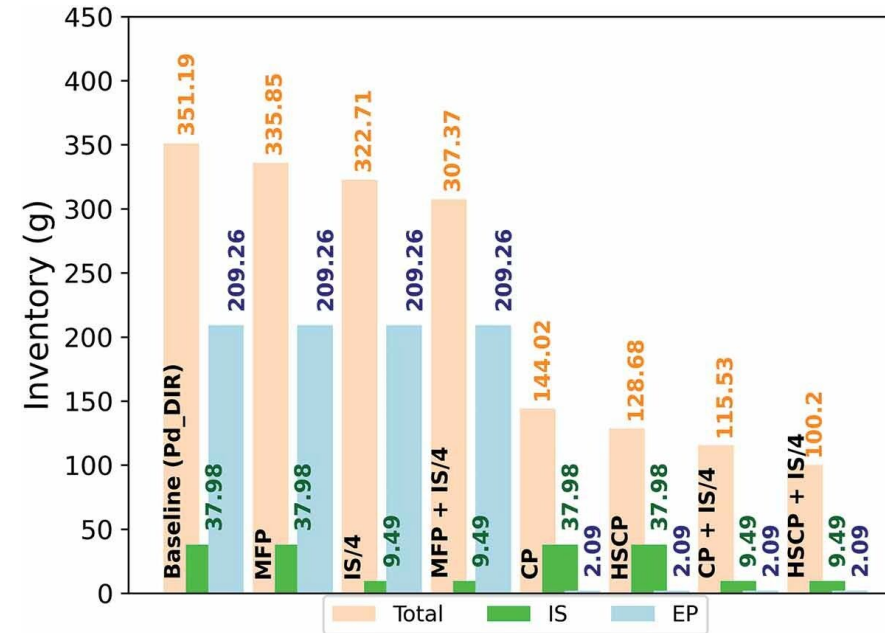
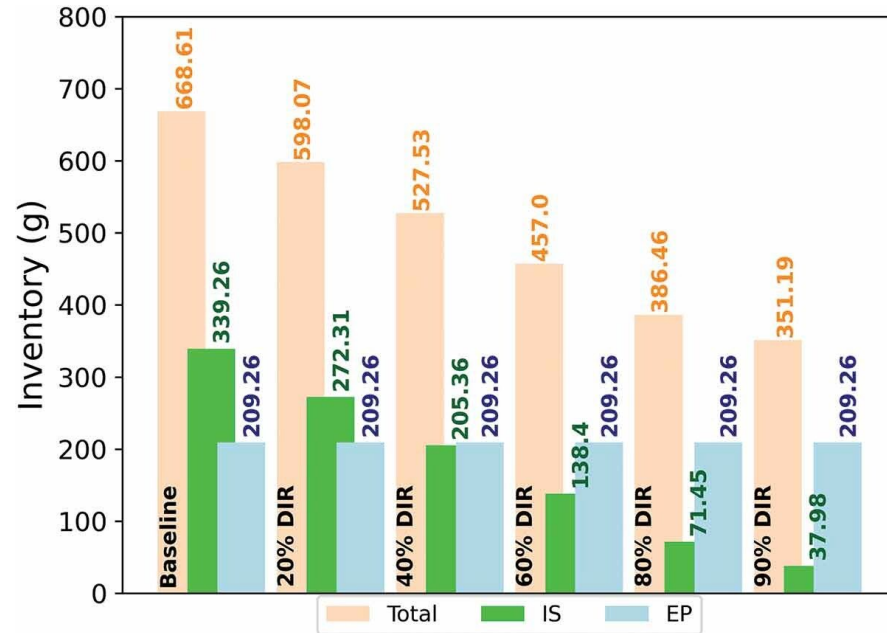

- The ability to recycle any fraction of the exhaust reduces inventory (limited by isotopic imbalance)
- There are several approaches to DIR: (1) Metal foil pumps; (2) Snail pumps; (3) Palladium Diffusers
  - MFP and snail pumps combine pumping with recycling
  - Palladium diffusers recycle immediately after the pumps
- Inventory reductions are essentially the same whether separation occurs in the pump or immediately after

# Deuterium Tritium Fuel Cycle: Isotope Separation

- Fuel cycle exists because:
  - Fusion burnup is low
  - Tritium is rare
- Challenging because:
  - Tritium is radioactive
  - Behaves like hydrogen
- Fuel cycle is similar between different fusion approaches
  - But minor differences may have large impacts on scale and technologies

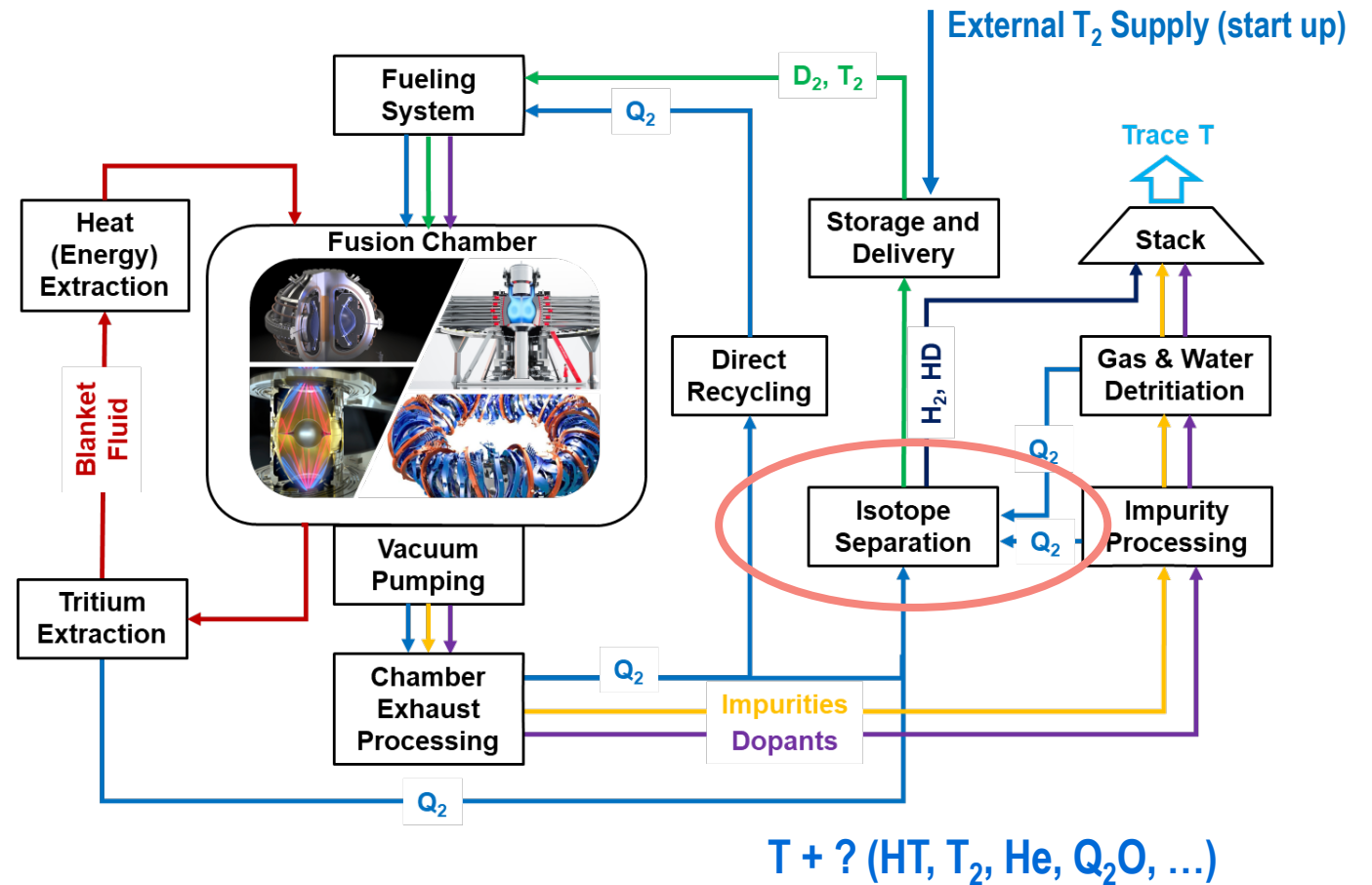

Recent excellent review on different approaches: Shere, Lawrence, et al. "The next generation of low tritium hydrogen isotope separation technologies for future fusion power plants." *Int. J. of Hydrogen Energy* (2023).

# Cryogenic Distillation (CD)

- Cryogenic Distillation (CD) Typically Used
  - $H_2$ , HD, HT,  $D_2$ , DT,  $T_2$  have slightly different boiling points
    - 20.39 K, 22.14 K, 22.92 K, 23.66 K, 24.38 K, 25.05 K
- Multiple Input Streams
  - Exhaust and Water Processing Purposes
    - Recover D & T for reuse
    - Remove H for Stacking (some D is also stacked)
- Typically Multiple (4), Distillation Columns
  - Multiple Feed and Withdrawal Points – depends on gas composition
  - Equilibrators: e.g.  $HT + D_2 \leftrightarrow HD + DT$
  - Integrated Operation with Water Detritiation Process

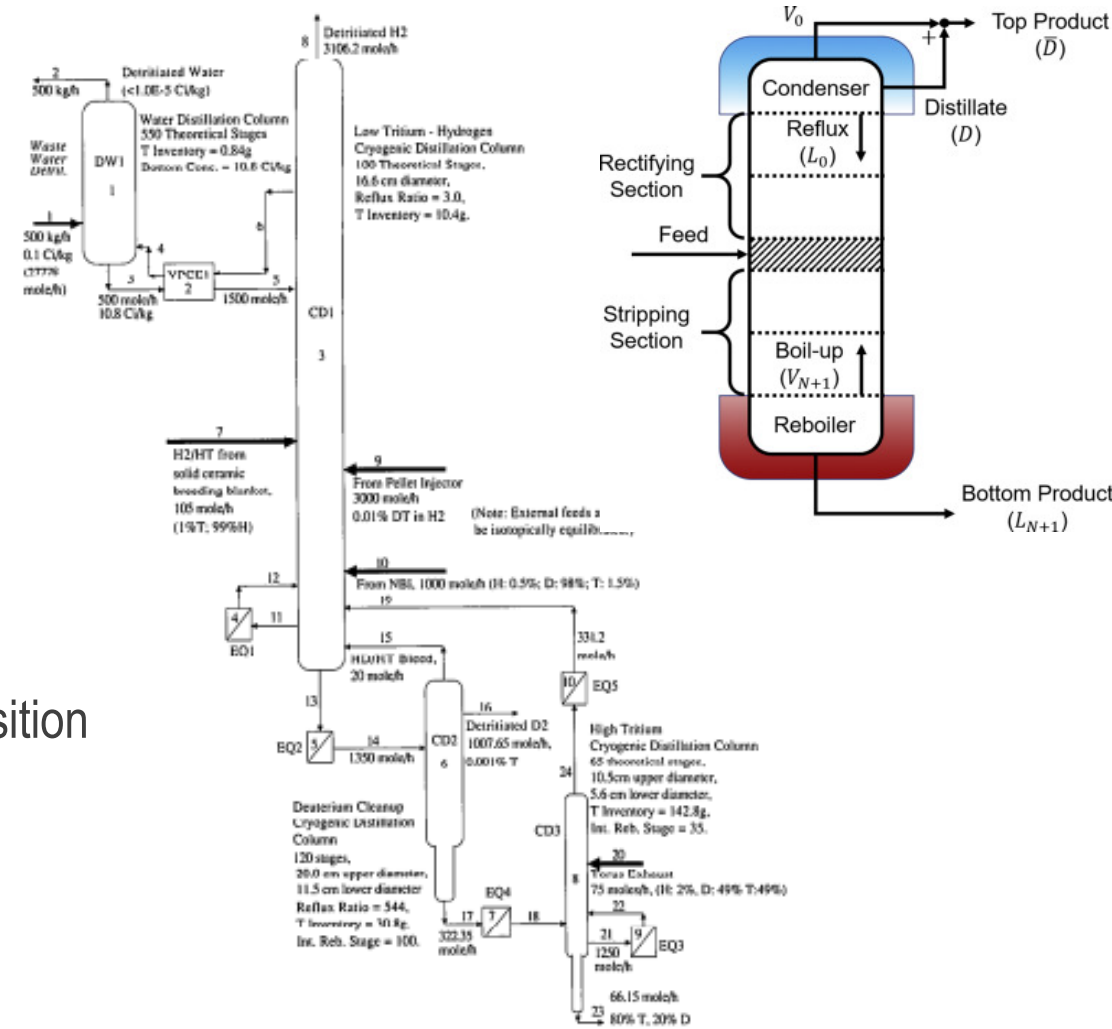

# Isotope Separation System (ISS) - TCAP Technology

## Thermal Cycling Absorption Process

- Function
  - Produce high purity tritium
  - Produce tritium-free deuterium (and protium) for discharge or recycle
- Principle
  - Palladium's preferential hydrogen isotopic absorption ( $H > D > T$ ), especially at low temperatures
  - Molecular sieve has opposite isotopic effect at low temperatures
  - Semi-continuous operation, thermal cycling
- Advantages
  - Moderate temperature and pressure
  - Compact, low inventory, simple operation
  - Liquid nitrogen cooling, electric heating

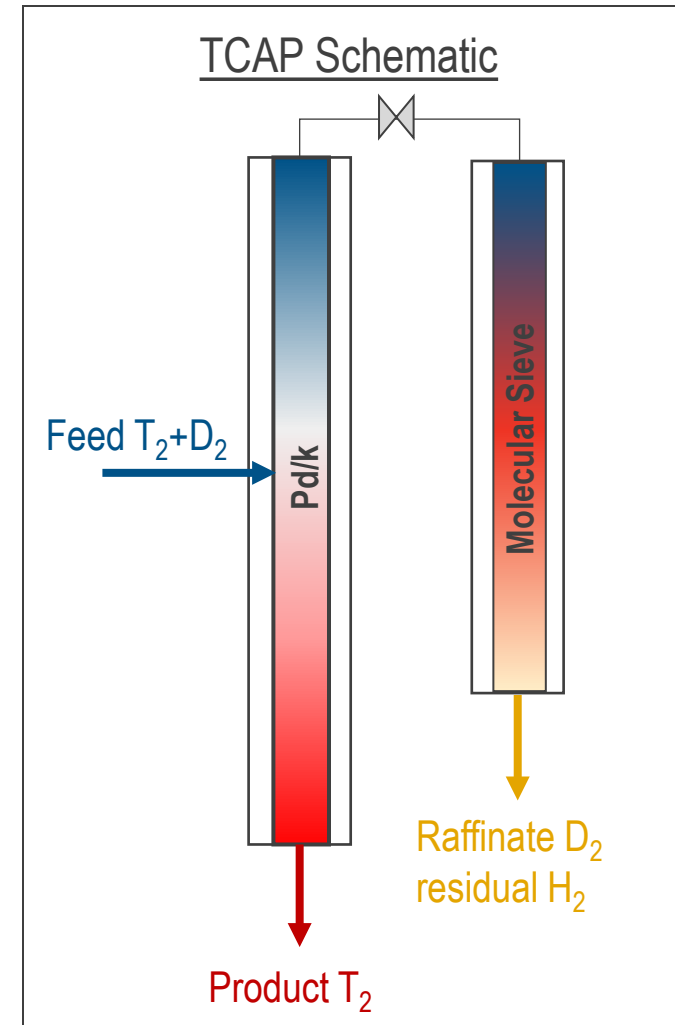

# TCAP

- TCAP will need to be scaled up to meet the needs of fusion plants
- Improved thermal management is needed for scale up
  - Heat generation due to hydrogen sorption; Large temperature swings
- Functional materials properties are unexplored areas for TCAP scale up
  - Materials development could offer opportunity for improvement in throughput

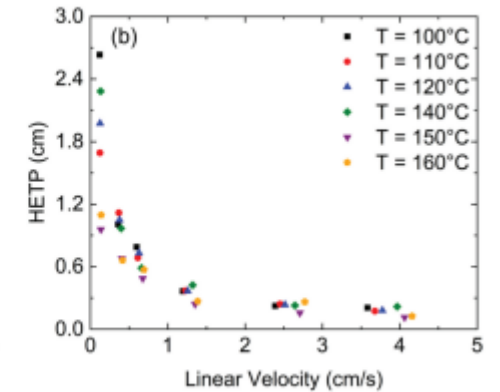
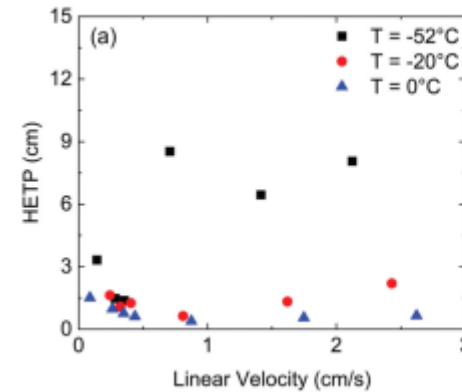
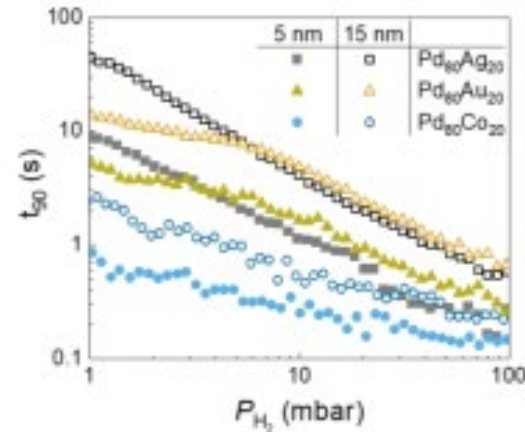
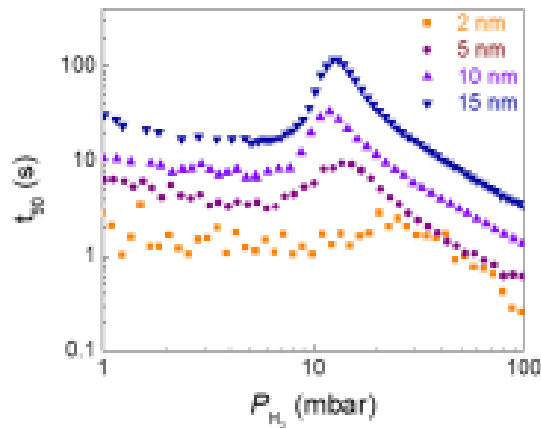

# Deuterium Tritium Fuel Cycle: Impurity Processing

- Fuel cycle exists because:
  - Fusion burnup is low
  - Tritium is rare
- Challenging because:
  - Tritium is radioactive
  - Behaves like hydrogen
- Fuel cycle is similar between different fusion approaches
  - But minor differences may have large impacts on scale and technologies

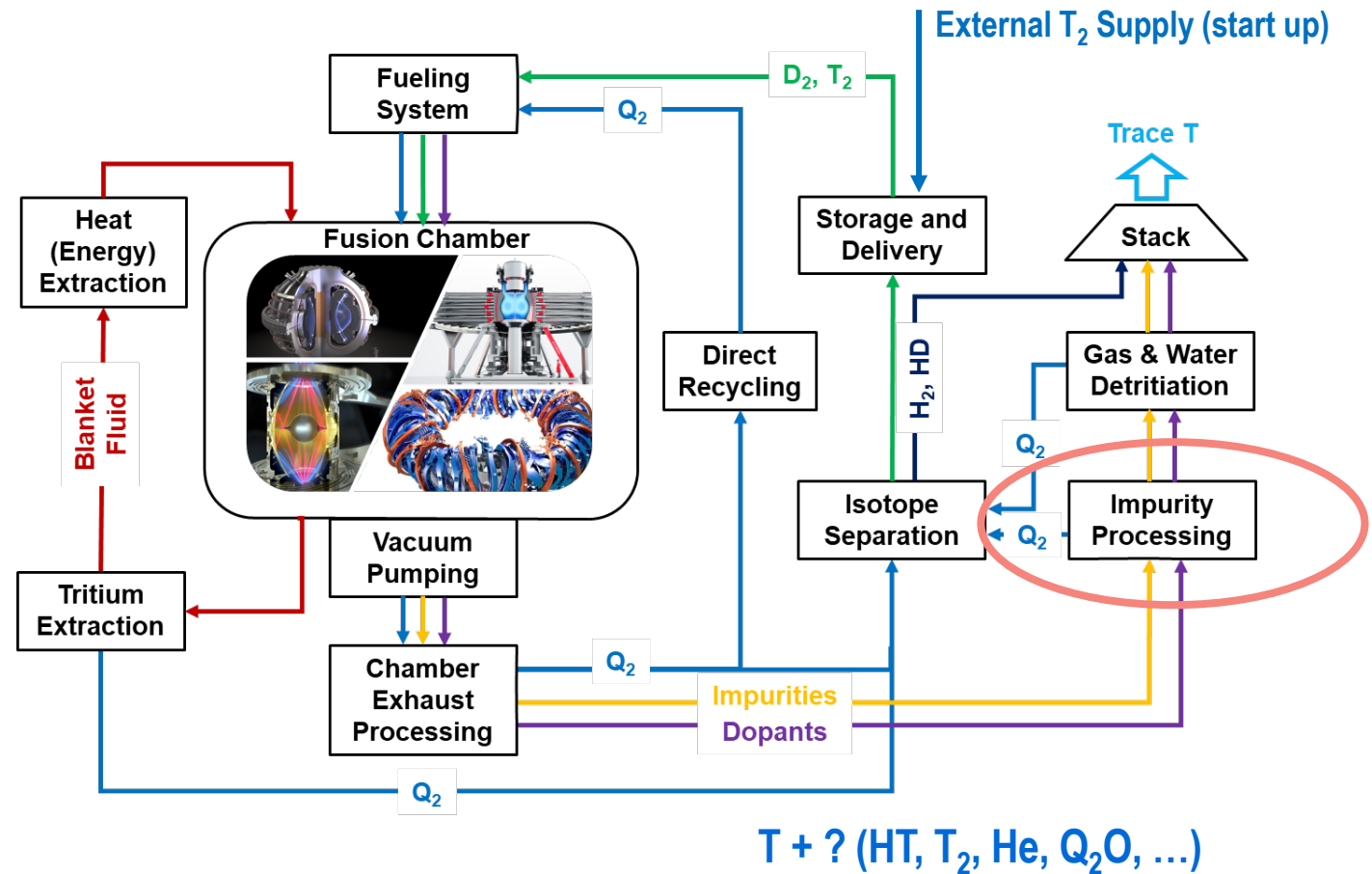

*Goal: Supply chamber with DT fuel within specifications, while minimizing emissions*



# Palladium Membrane Reactor (PMR) Impurity Processing

- Used for Tritium Recovery Reactions
  - Methane Steam Reforming (MSR) Reaction:  $\text{CQ}_4 + \text{H}_2\text{O} \leftrightarrow 3\text{Q}_2 + \text{CO}$
  - Water-Gas Shift (WGS) Reaction:  $\text{Q}_2\text{O} + \text{CO} \leftrightarrow \text{Q}_2 + \text{CO}_2$
- Reaction Conversion Limited by Equilibrium
  - Pd membrane used to remove  $\text{Q}_2$  to increase WGS and MSR reaction conversions
    - $\text{CQ}_4 + \text{H}_2\text{O} \rightarrow \text{CO} (3\text{Q}_2)$
    - $\text{Q}_2\text{O} + \text{CO} \rightarrow \text{CO}_2 (\text{Q}_2)$
- “Diffuser/Permeator with Catalyst Packing”

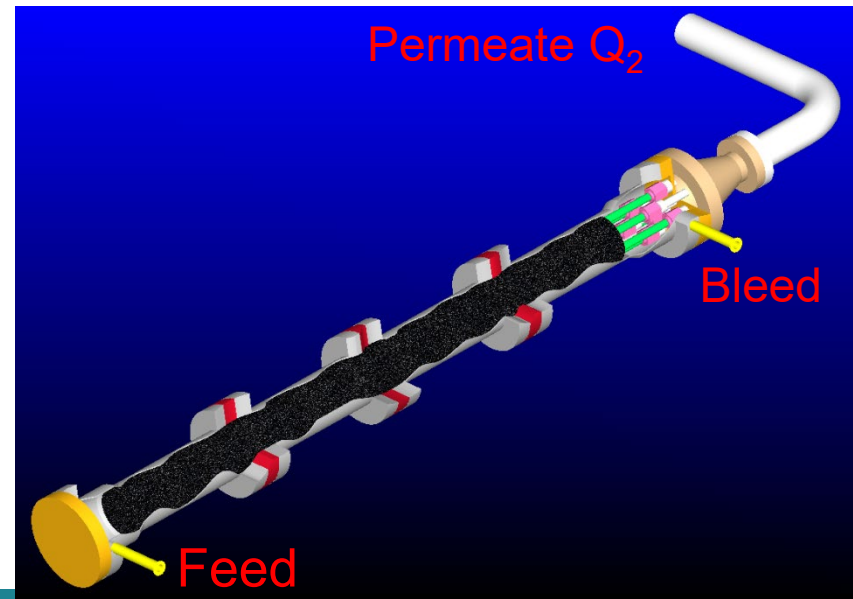
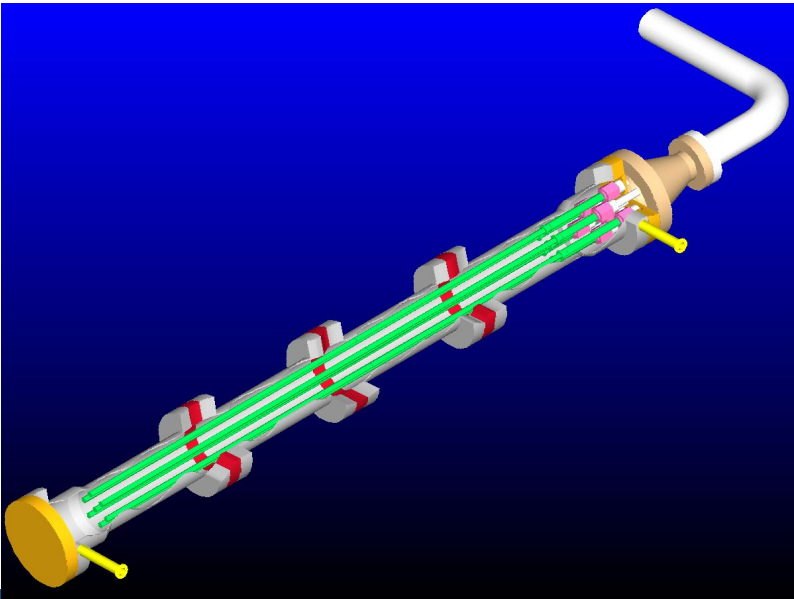

# PMR Processing for Ammonia

- Ammonia can be decomposed back into nitrogen and tritium through catalytic cracking.

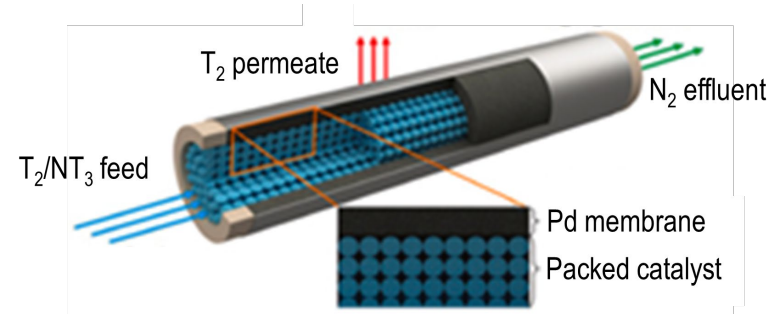
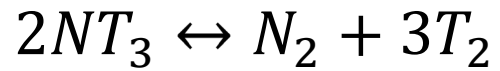

SRNL catalysts active <math><450^\circ\text{C}</math>

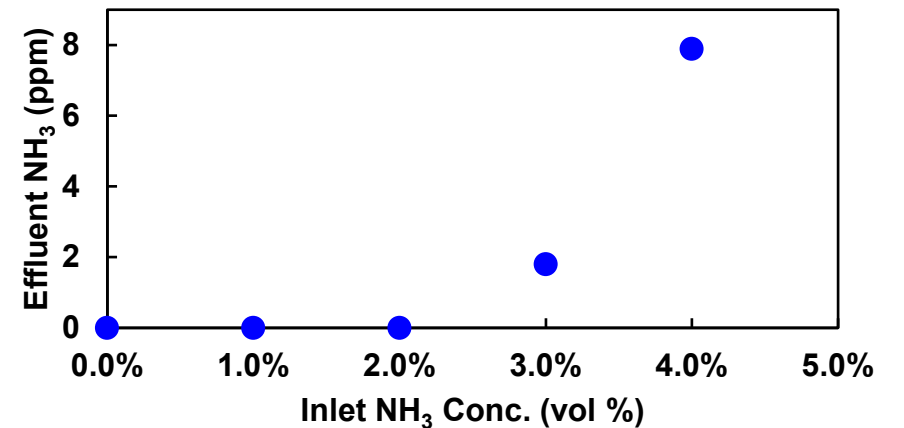
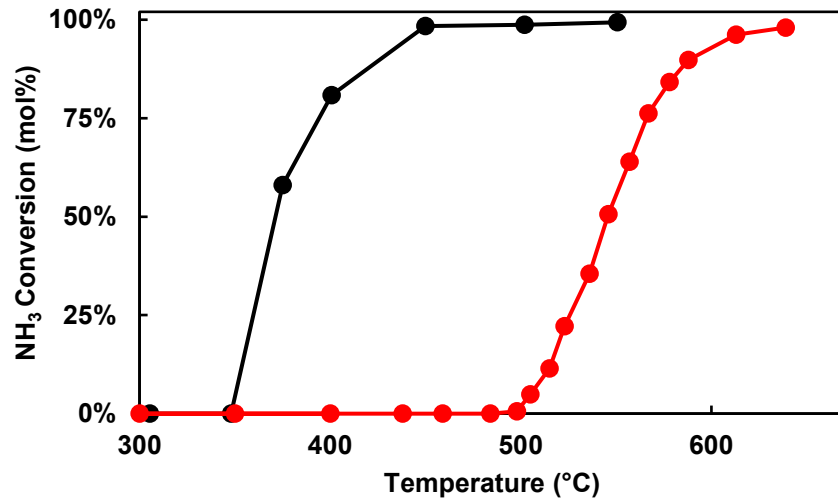

At  $450^\circ\text{C}$ , <1 ppm ammonia was detected at maximum flows. Reaction was limited by the permeation of the Pd-Ag, not catalyst.

# Water Detritiation by the Liquid Phase Catalytic Exchange Process

- Isotope exchange takes place in two sections
  - Catalytic section:  $HT + (H_2O)_v \rightarrow (HTO)_v + H_2$
  - Scrubbing section  $(HTO)_v + (H_2O)_l \rightarrow (H_2O)_v + (HTO)_l$

Water detritiation is difficult and capital intensive

- c.f. Fukushima

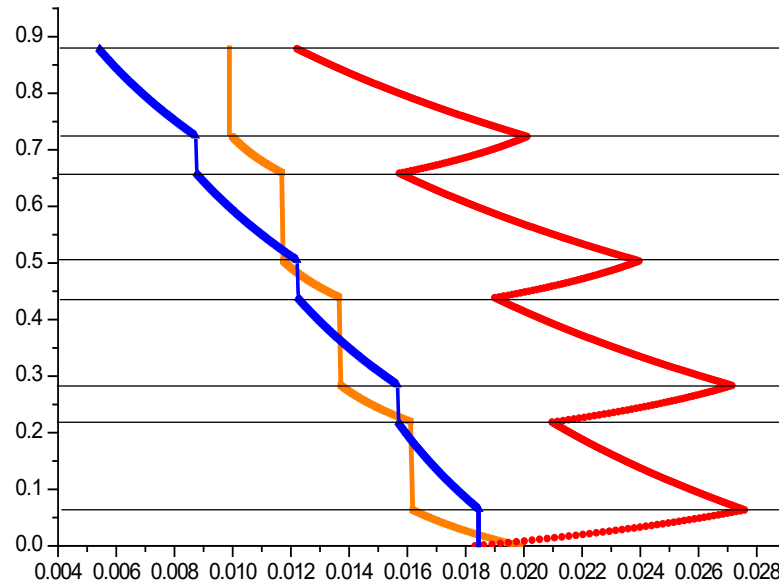
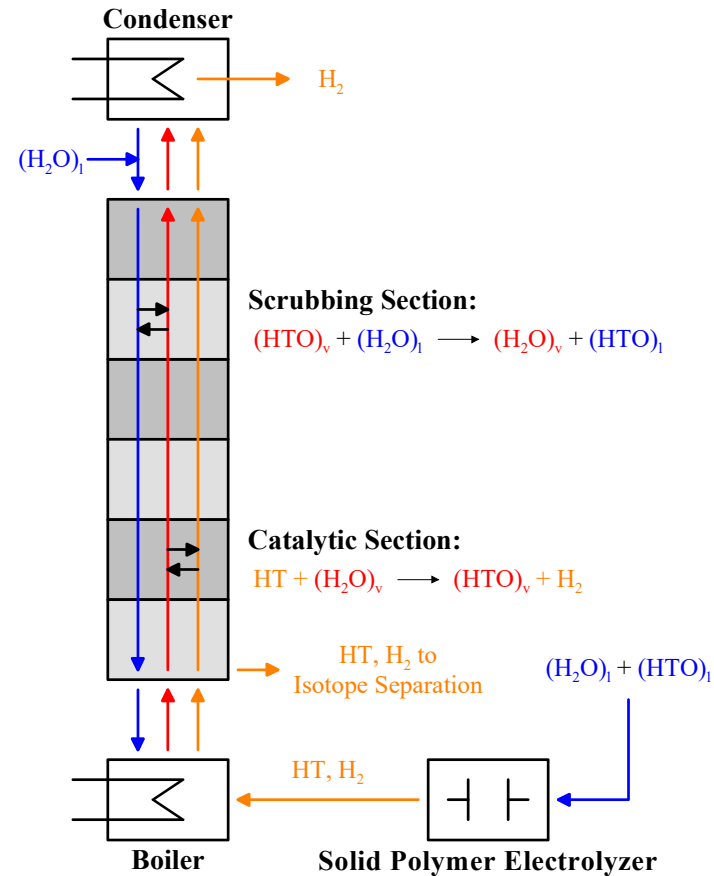

Courtesy of Manfred Gugla

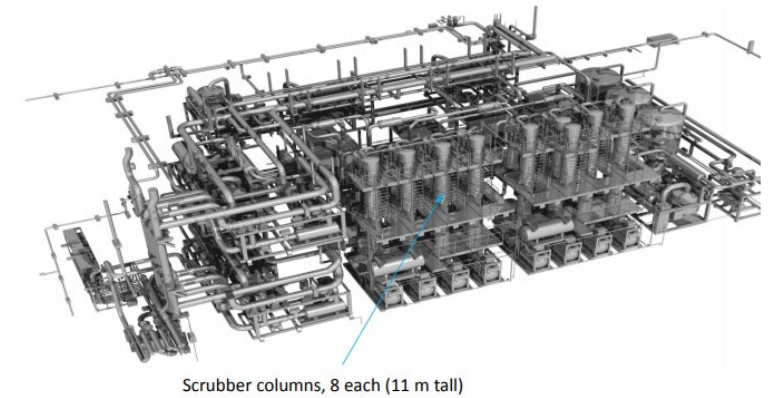

ITER's tokamak complex detritiation system



# Gas Detritiation Systems

- Stripper Systems Typically Convert Tritiated Compounds (e.g.  $\text{Q}_2$ ,  $\text{CQ}_4$ ) to Water ( $\text{Q}_2\text{O}$ )
- Tritiated Water Is Collected (MS= Molecular Sieve) and Then Processed Separately
- Tritiated Water Is Stripped (SC= Scrubber Column) and Then Processed Separately

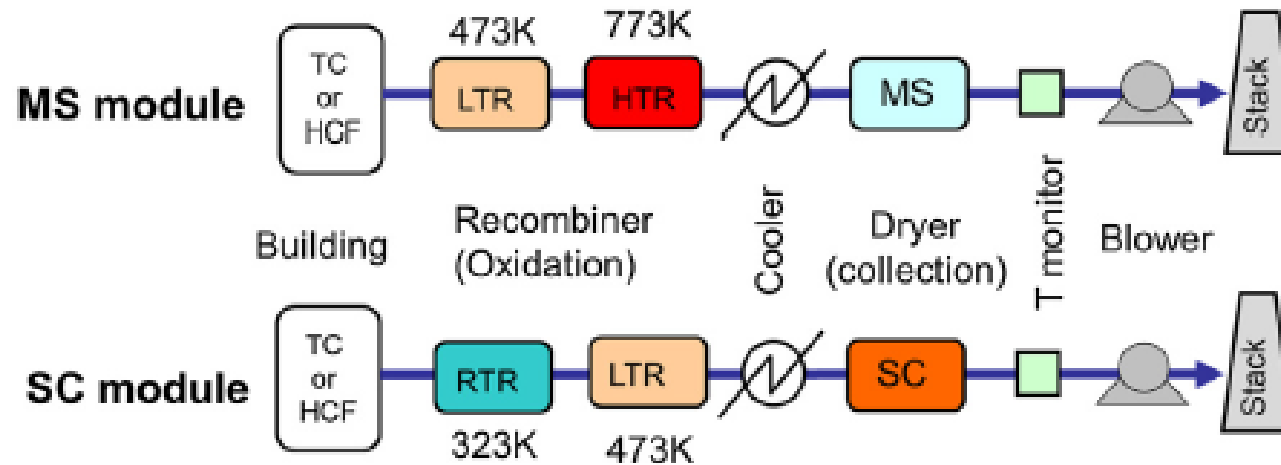

**Fig. 4.** Two detritiation systems designed for ITER, where TC and HCF mean Tokamak complex building and hot cell facility, respectively, and RTR, LTR and HTR mean catalytic oxidation reactors at their respective (room, low and high) temperatures [22].

# Six Fuel Cycle Research Topics (Based on FESAC, NASEM, Decadal Vision, FC/B Workshops)

- **Process Modeling, Process Control, & Simulation** – Define models to advance & optimize system design, monitor operation, control the process and simulate performance during normal and off-normal operation
- **Tritium Inventory Reduction & Improved Process Technologies** – Improve tritium processing (including development methods of internal recycling) to reduce the inventory needed and lower the radioactive source term.
- **Isotope Supply, Tritium Breeding, and Tritium Extraction** – Define tritium/isotope supply source and processing, ensure tritium breeding ratio can be achieved, and minimize captive inventory
- **Tritium Confinement to Reduce Emissions and Tritium Effects on Materials** – Develop advanced tritium wetted materials and confinement barriers; understand and mitigate tritium retention and permeation; and improve tritium removal and recovery from secondary/tertiary confinements and effluent streams
- **Tritium Accountability and Tritium Analytical/Diagnostic Capabilities** – Develop rapid, high-accuracy/precise accountability measurement instruments and techniques to measure tritium and account for it in different parts of the system
- **Fusion Waste, Regulation, Non-Proliferation, Community Engagement** – Support the development of regulations for fusion related to tritium, non-proliferation, and waste. Improve material selection and tritium decontamination to support waste disposal and the safety basis.

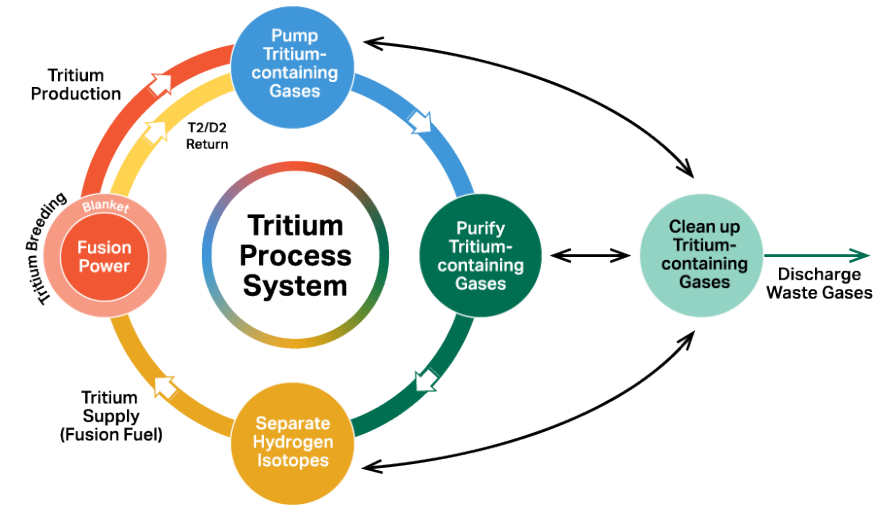

# Deuterium Tritium Fuel Cycle: Tritium Breeding and Extraction

- Fuel cycle exists because:
  - Fusion burnup is low
  - Tritium is rare
- Challenging because:
  - Tritium is radioactive
  - Behaves like hydrogen
- Fuel cycle is similar between different fusion approaches
  - But minor differences may have large impacts on scale and technologies

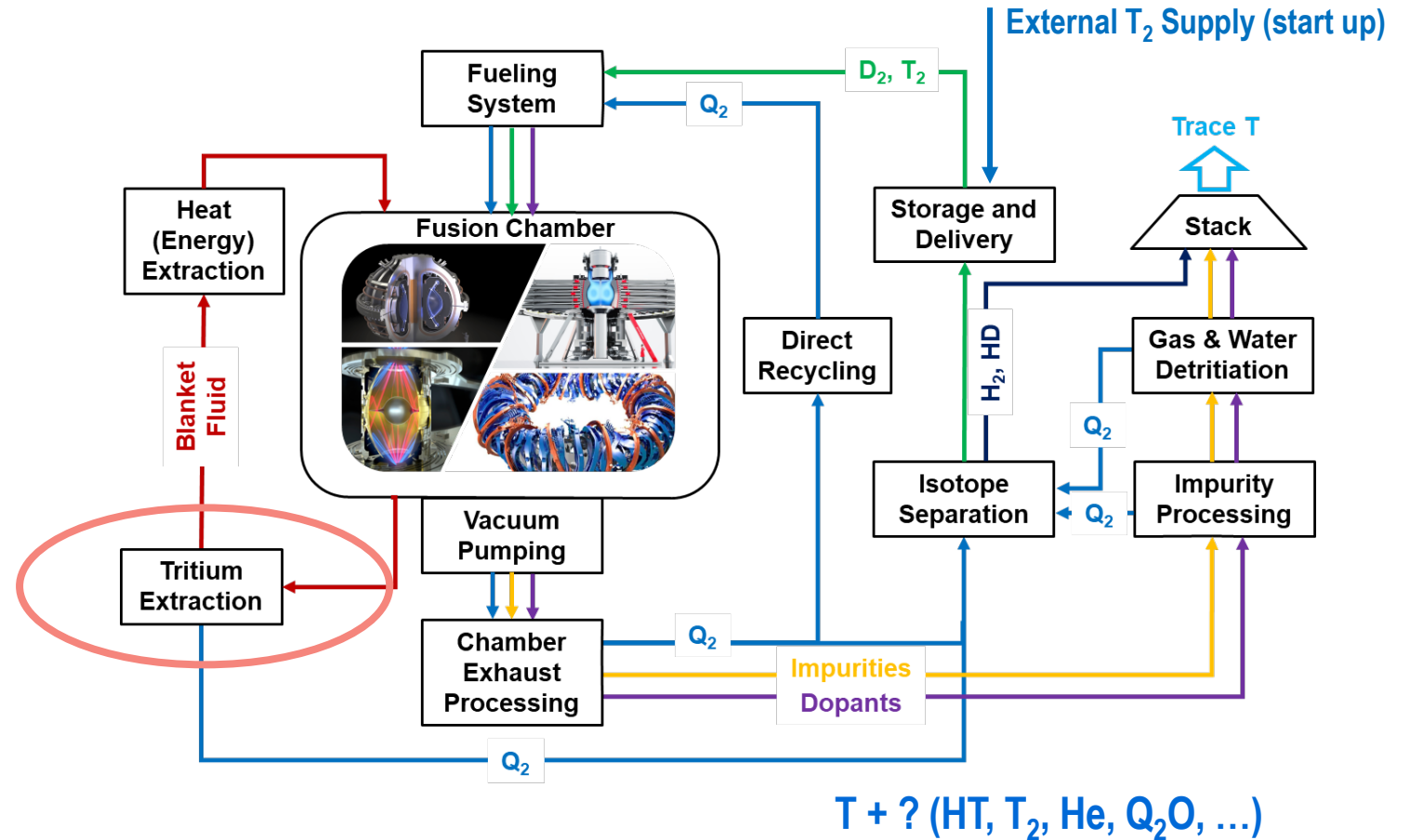

*Goal: Supply chamber with DT fuel within specifications, while minimizing emissions*



# Tritium Breeding Blanket Functions

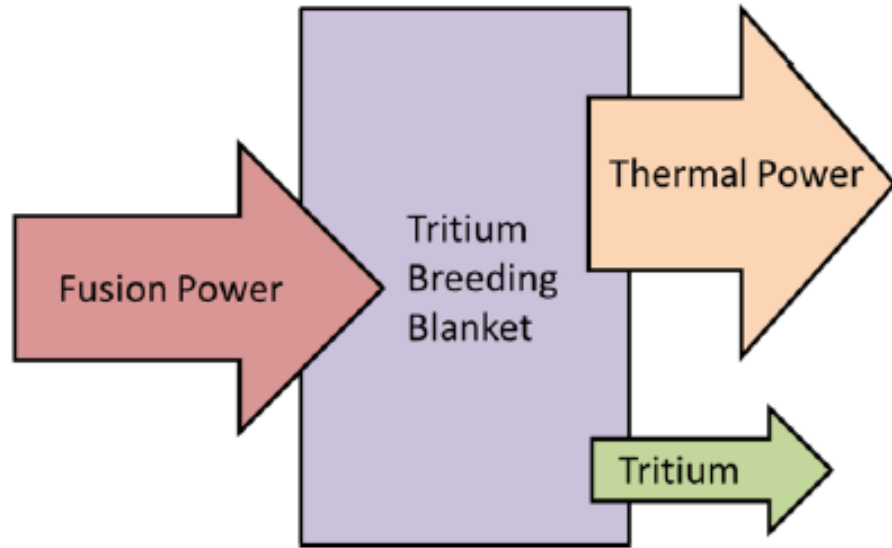

Essential functions of the Breeding Blanket

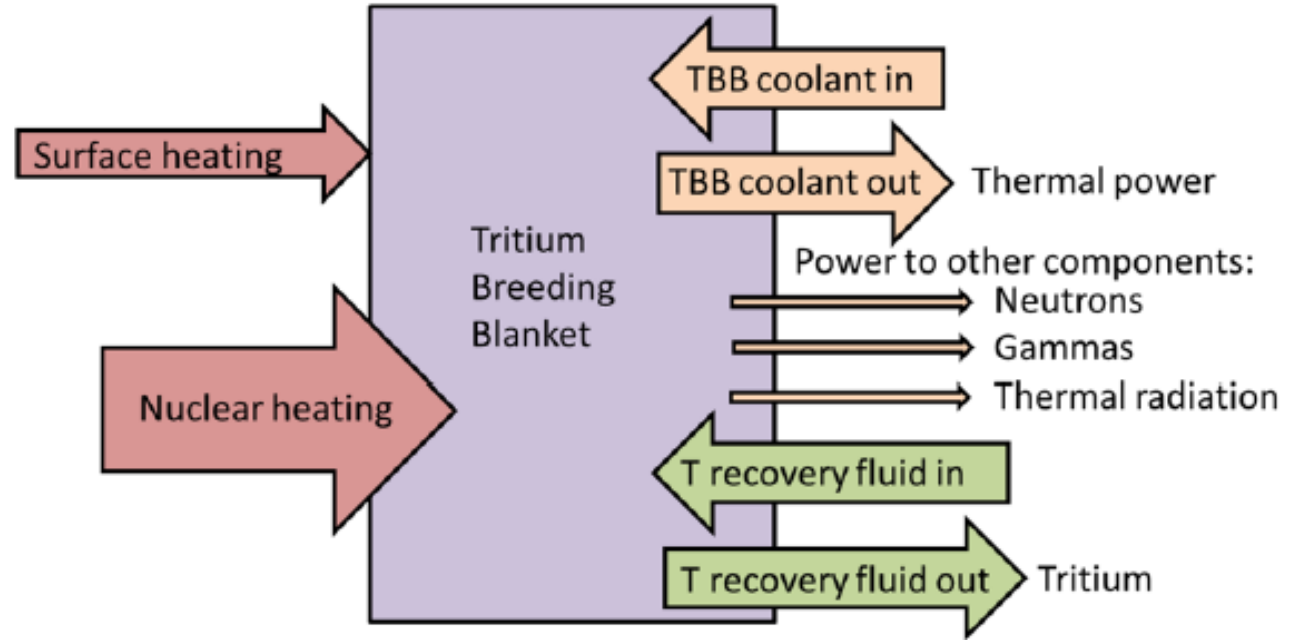

Schematic of level inputs and outputs of the Breeding Blanket

W.R. Meier, LLNL-TR-658973-REV-1, (2014)

# Tritium Breeding Blanket

Tritium Breeder	Key Properties	Features/Advantages	Issues
Li	Liquid metal, $T_{\text{melt}} = 181\text{C}$	<ul style="list-style-type: none"> <li>High TBR potential</li> <li>Dual function, also used as coolant</li> <li>Good heat transfer properties</li> <li>Low melting point</li> <li>Neutron multiplier not needed</li> <li>Affinity for T, low permeation losses</li> </ul>	<ul style="list-style-type: none"> <li>Chemically reactive, burns with air and water, safety issue</li> <li>T recovery more difficult due to being tightly bound to Li</li> <li>Liquid metal corrosion of structures</li> </ul>
PbLi	Liquid metal, $T_{\text{melt}} = 235\text{C}$	<ul style="list-style-type: none"> <li>Good TBR potential</li> <li>Dual function, also used as coolant</li> <li>Good heat transfer material</li> <li>Acceptable melting point</li> <li>Pb serves as neutron multiplier</li> <li>Less reactive than Li (safer)</li> <li>Low T solubility, ease of T recovery</li> </ul>	<ul style="list-style-type: none"> <li>High density leads to high mass TBB, structural implications</li> <li>Special measures need to limit T permeation losses</li> <li>Liquid metal corrosion</li> </ul>
Flibe	Molten salt, $T_{\text{melt}} = 300\text{C}$	<ul style="list-style-type: none"> <li>Marginal TBR</li> <li>Dual function, also used as coolant</li> <li>Good heat transport capability</li> <li>Be serves as neutron multiplier</li> <li>Better safety than Li</li> <li>Ease of T recovery (like PbLi)</li> </ul>	<ul style="list-style-type: none"> <li>Expensive</li> <li>Low heat transfer coefficient</li> <li>Special measures need to limit T permeation losses</li> <li>Corrosion</li> </ul>
Ceramics (e.g., $\text{Li}_4\text{SiO}_4$ , $\text{Li}_2\text{TiO}_3$ , etc.)	Ceramic pebbles	<ul style="list-style-type: none"> <li>Acceptable TBR</li> <li>Compatible with most structural materials</li> <li>High temperature operation, high efficiency possible.</li> </ul>	<ul style="list-style-type: none"> <li>Requires neutron multiplier</li> <li>Radiation damage may impact ease of T recovery</li> <li>Requires separate He purge loop for T recovery</li> </ul>

← Functional Materials

Neutron Multipliers

Neutron Multipliers	Key Properties	Features/Advantages	Issues
Be	Metal typically in pebble form	<ul style="list-style-type: none"> <li>Very good neutron multiplier</li> </ul>	<ul style="list-style-type: none"> <li>Expensive</li> <li>Resource limited</li> <li>Handling care needed</li> </ul>
Pb	Liquid metal $T_{\text{melt}} = 328\text{C}$	<ul style="list-style-type: none"> <li>Good multiplier</li> </ul>	<ul style="list-style-type: none"> <li>Produces activation product Po</li> </ul>
Pb as part of PbLi	Liquid metal	<ul style="list-style-type: none"> <li>Can serve functions of breeding, coolant and tritium removal</li> </ul>	<ul style="list-style-type: none"> <li>Produces activation product Po</li> </ul>
$\text{Be}_{12}\text{Ti}$	Intermetallic	<ul style="list-style-type: none"> <li>Almost as good as Be, higher operating temp</li> </ul>	<ul style="list-style-type: none"> <li>Expensive</li> <li>Resource limited</li> <li>Handling care needed</li> </ul>

W.R. Meier, LLNL-TR-658973-REV-1, (2014)

# SRNL Direct LiT Electrolysis (LDRD, ARPA-E GAMOW)

## Maroni Process

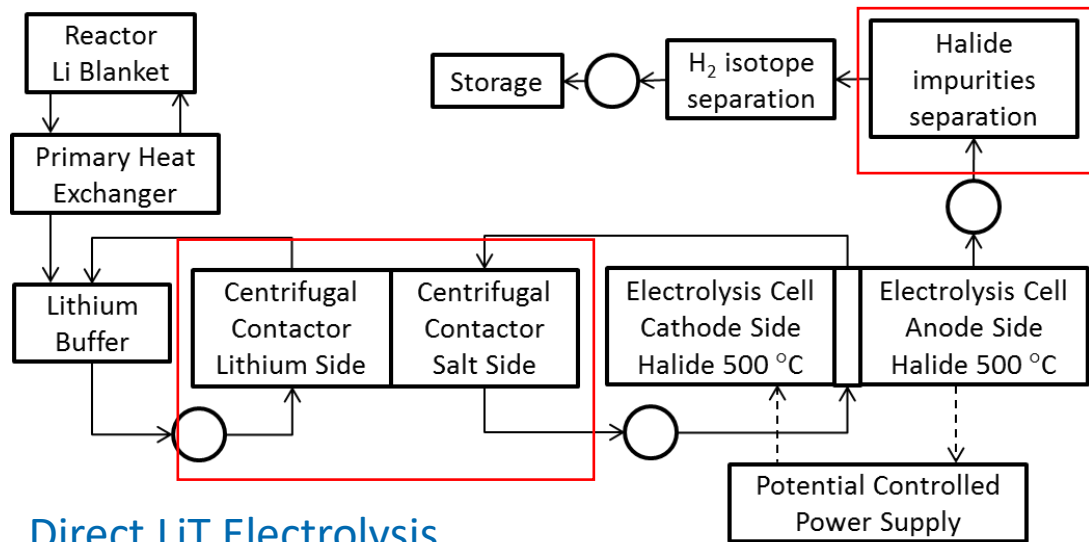

## Direct LiT Electrolysis

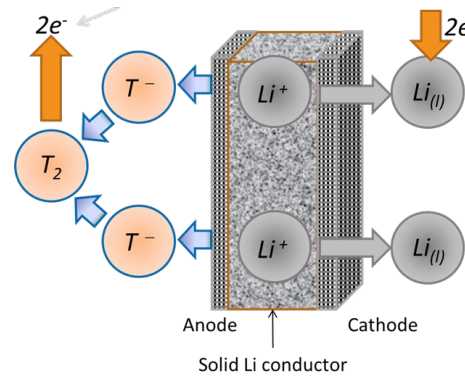
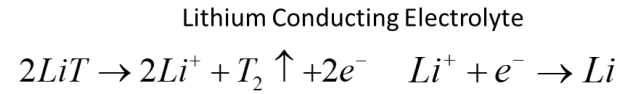
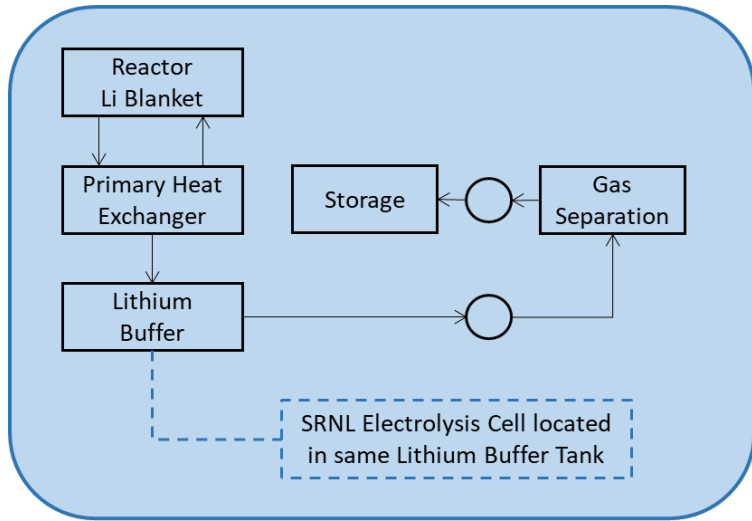

$$E_{400^\circ C}^0 = -2.82V$$

$$E_{400^\circ C}^0 = -3.22V$$

## Lithium Buffer Tank

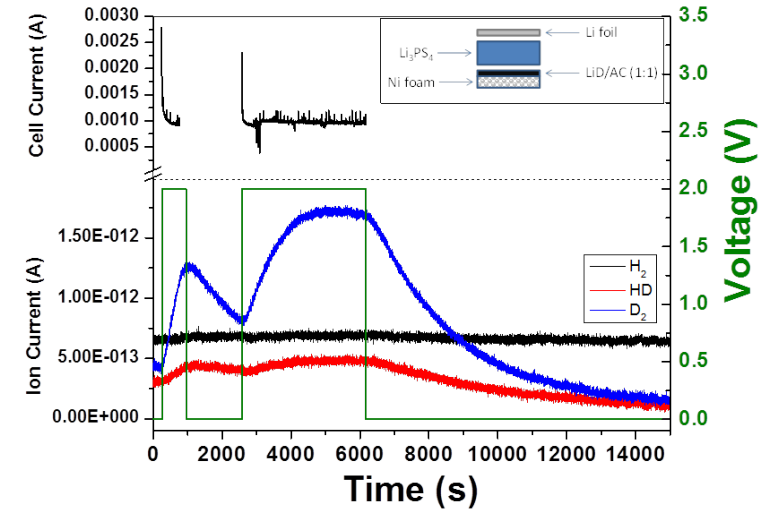
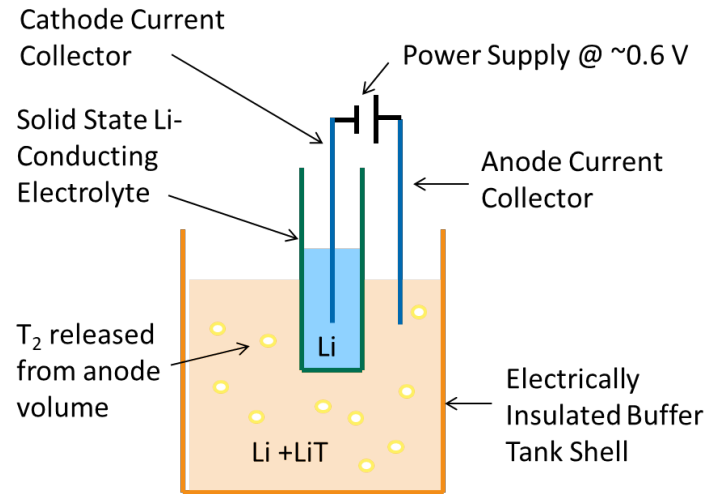

J. A. Teprovich, H. R. Colon-Mercado, L. Olson, P. Ganesan, D. Babineau, B. L. Garcia-Diaz, "Electrochemical extraction of hydrogen isotopes from Li/LiT mixtures," *Fusion Engineering and Design*, 139, 1-6, 2019.

# FLiBe: beryllium metal contact will react with TF to form T<sub>2</sub>, TH, etc. that can be extracted

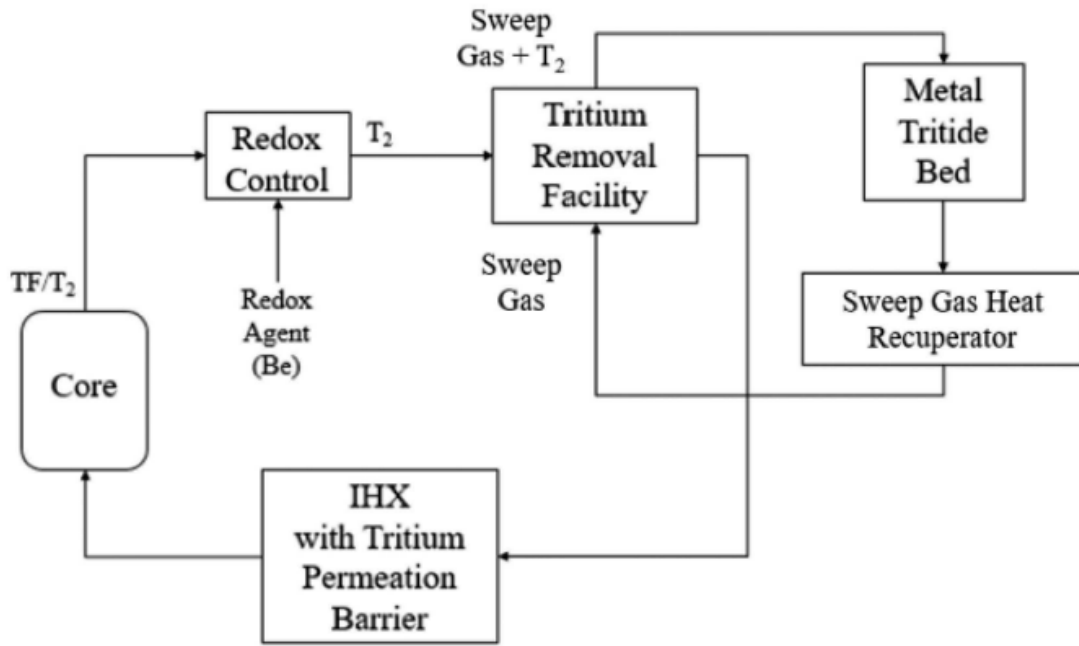
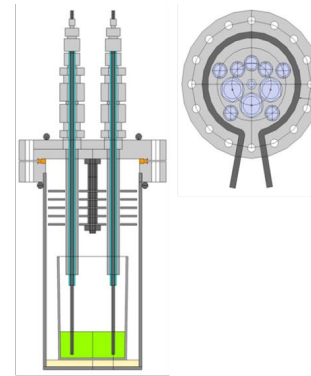
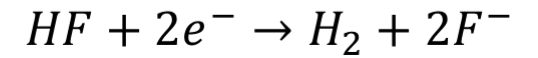
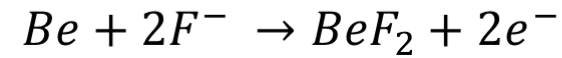
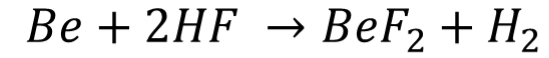
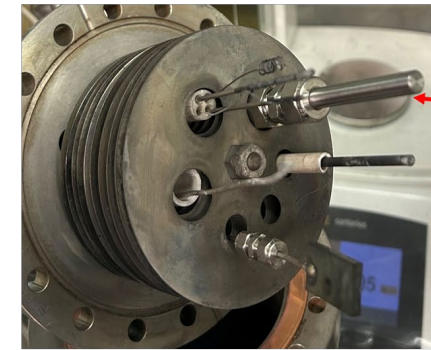

Fig. 8. Schematic of the tritium control and mitigation system.

Forsberg, et al., (2020) Fusion Blankets and Fluoride-Salt-Cooled High-Temperature Reactors with FLiBe Salt Coolant: Common Challenges, Tritium Control, and Opportunities for Synergistic Development, Strategies Between Fission, Fusion, and Solar Salt Technologies, Nuclear Technology, 206:11, 1778-1801, DOI: 10.1080/00295450.2019.1691400



Simplified EChem cell schematic



Sample of electrodes used in FLiBe tests



FLiBe post test

# FLiBe: T removal process improvements

## State of the art

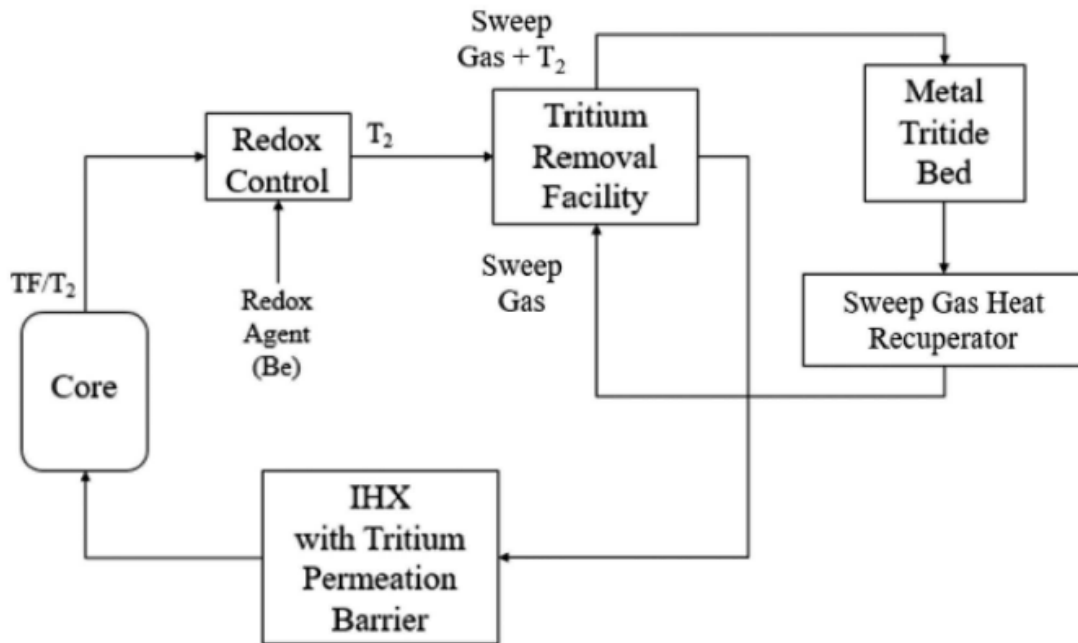
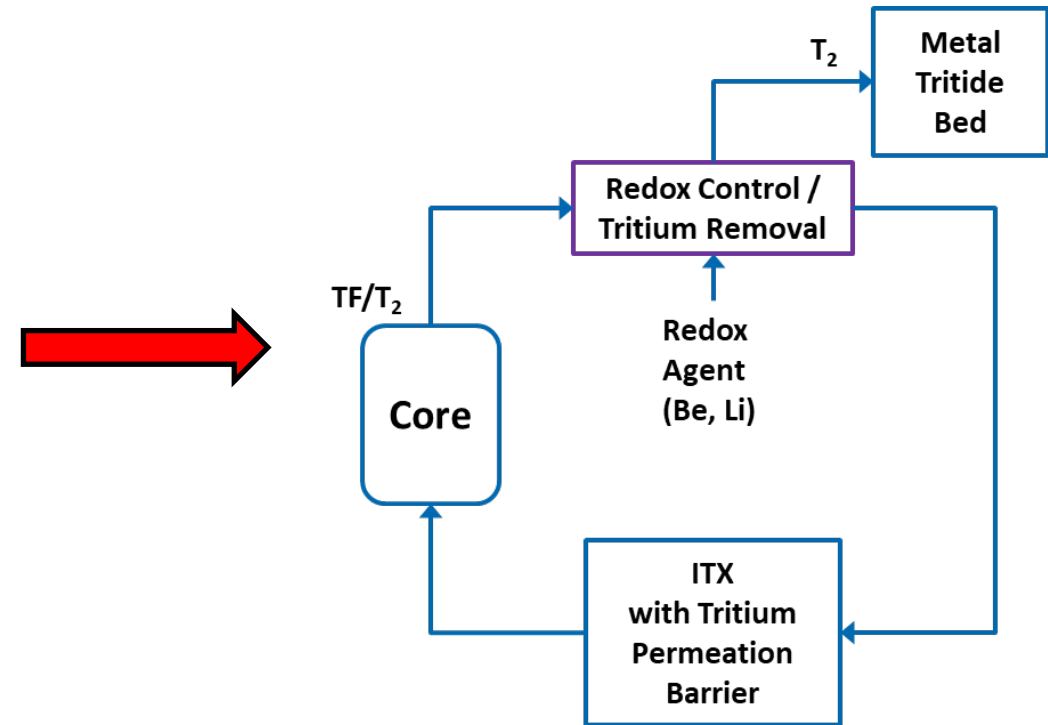

Fig. 8. Schematic of the tritium control and mitigation system.

## Combined Redox Control and Extraction (CoRExt) Process (Patent Pending 17/969,060)



Forsberg, et al., (2020) Fusion Blankets and Fluoride-Salt-Cooled High-Temperature Reactors with FLiBe Salt Coolant: Common Challenges, Tritium Control, and Opportunities for Synergistic Development  
Strategies Between Fission, Fusion, and Solar Salt Technologies, Nuclear Technology, 206:11, 1778-1801, DOI: 10.1080/00295450.2019.1691400

# FLiBe: CoRExt Process (Patent Pending 17/969,060)

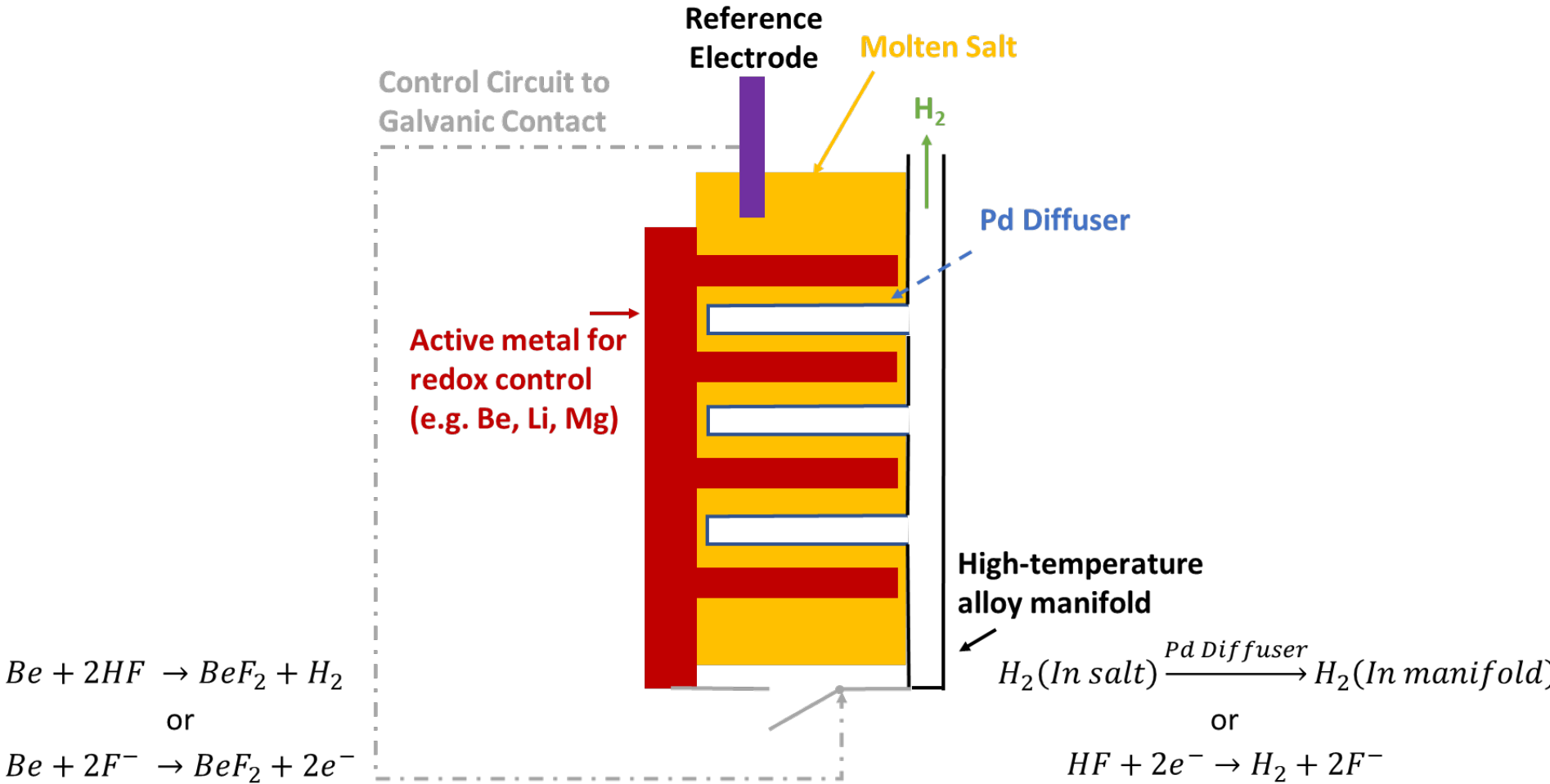

# Deuterium Tritium Fuel Cycle: Tritium Emissions

- Fuel cycle exists because:
  - Fusion burnup is low
  - Tritium is rare
- Challenging because:
  - Tritium is radioactive
  - Behaves like hydrogen
- Fuel cycle is similar between different fusion approaches
  - But minor differences may have large impacts on scale and technologies

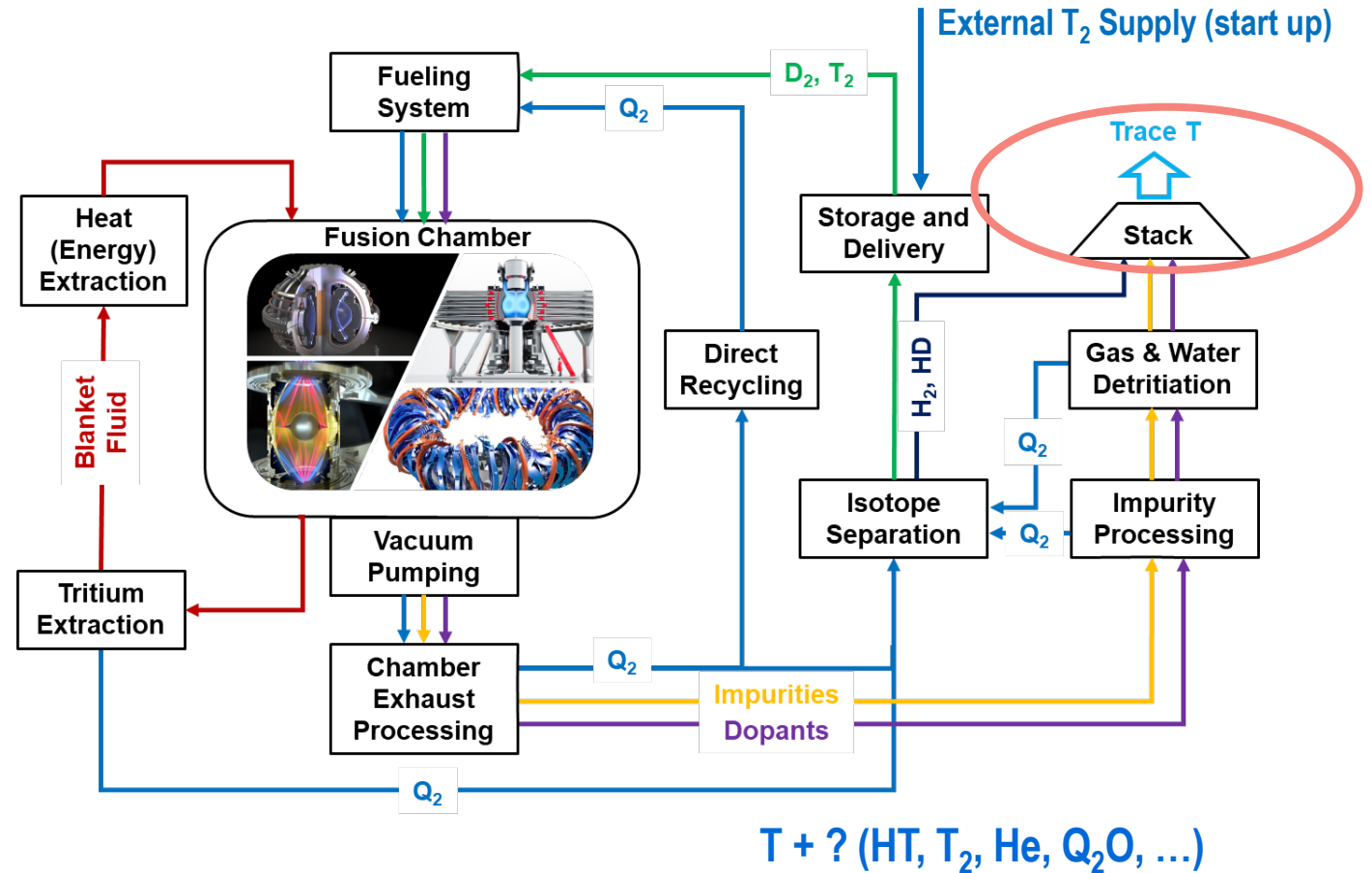

*Goal: Supply chamber with DT fuel within specifications, while minimizing emissions*

# Emissions from a multi-kilogram tritium processing facility



## Tritium Facility Radioactive Air Emissions Trend

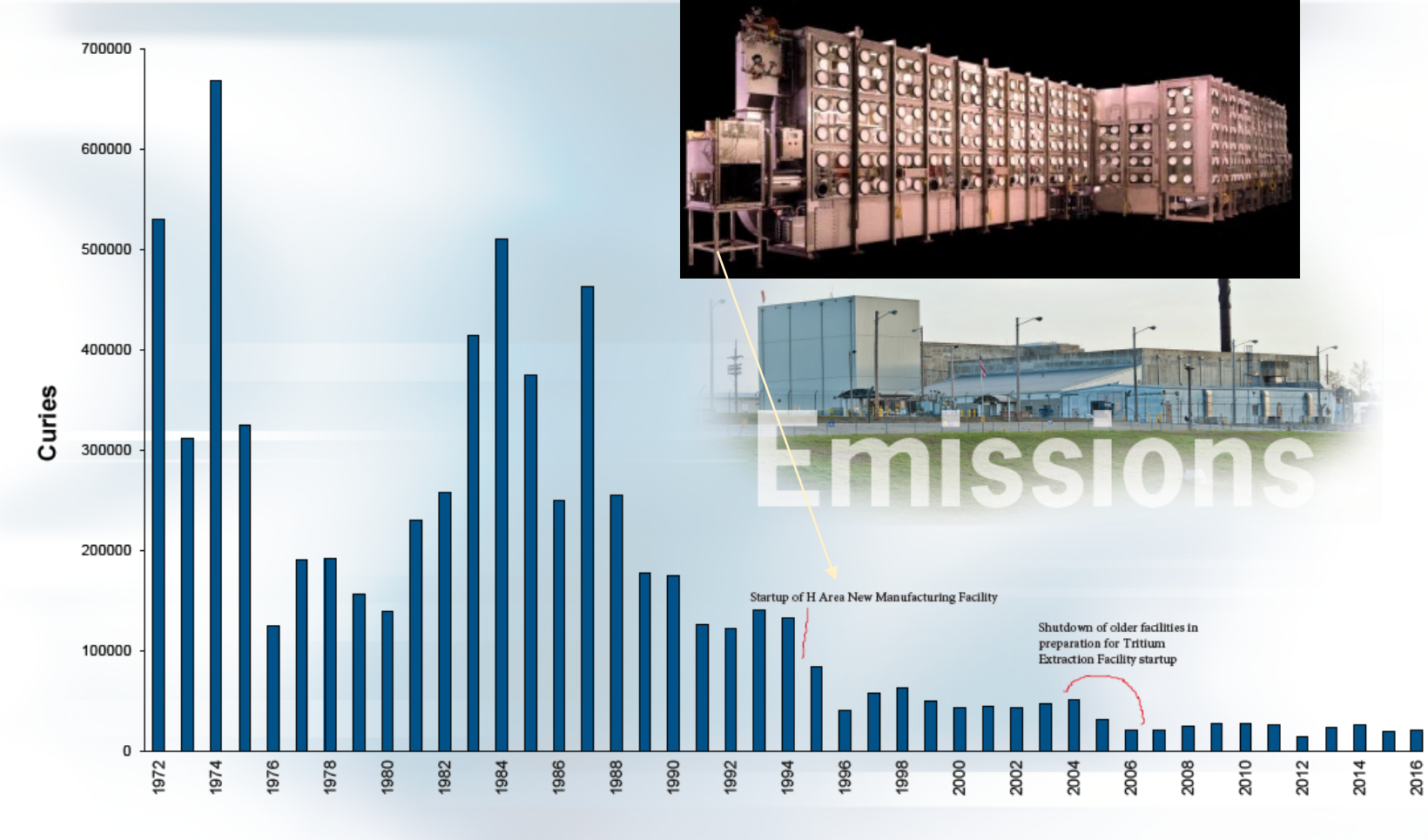

# Impact of DT Fusion Plants on Global Tritium Concentrations

- What is the impact of hundreds of fusion power plants across the globe releasing tritium?

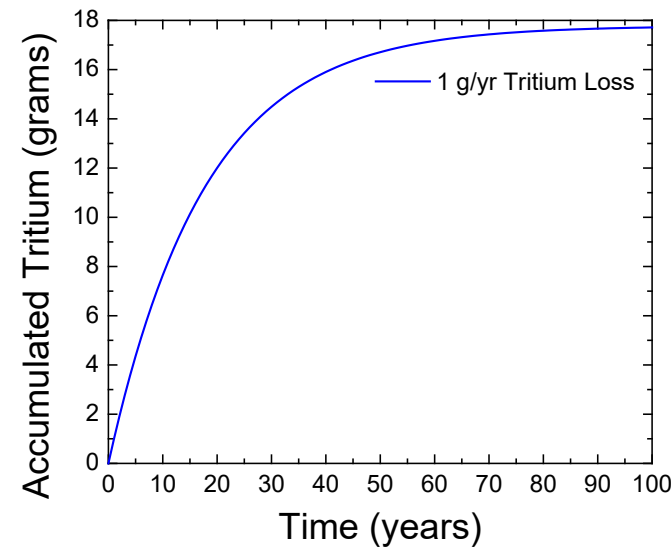
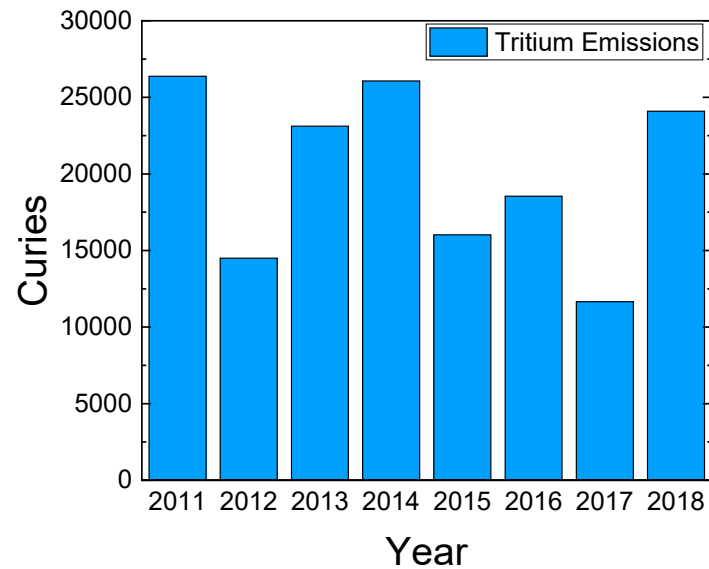

$$N(t) = \frac{p t_{1/2}}{\ln 2} (1 - e^{-\frac{t \ln 2}{t_{1/2}}}) = p \times 17.8$$

Studies estimate 0.05 – 6.18 g/yr from 500 MW Fusion Nuclear Science Facility (FNSF)

- **Emissions are unavoidable in a tritium processing facility**

- DOE Fusion Safety Standard guidelines

- *Off-site dose: 0.1 mSv/y*

- Emissions of 0.286 g/y (2760 Ci/y) for generic site (Humrickhouse and Merrill *FED* 2017)

- Guidance target is an order of magnitude lower than regulatory limits



# Seven Box Model – Initial Results

- Solve system of equations
  - 1 g/yr loss per 500 MW into atmosphere
  - Fusion power accounts for 50% of 2015 installed electrical capacity of seven members of ITER

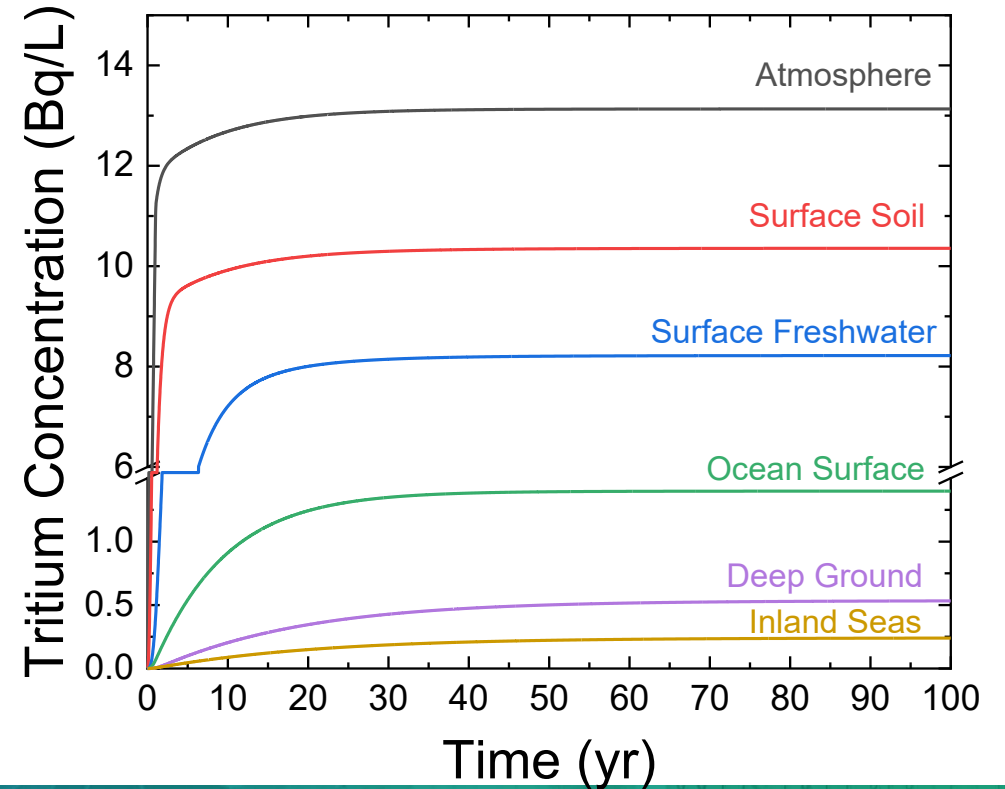
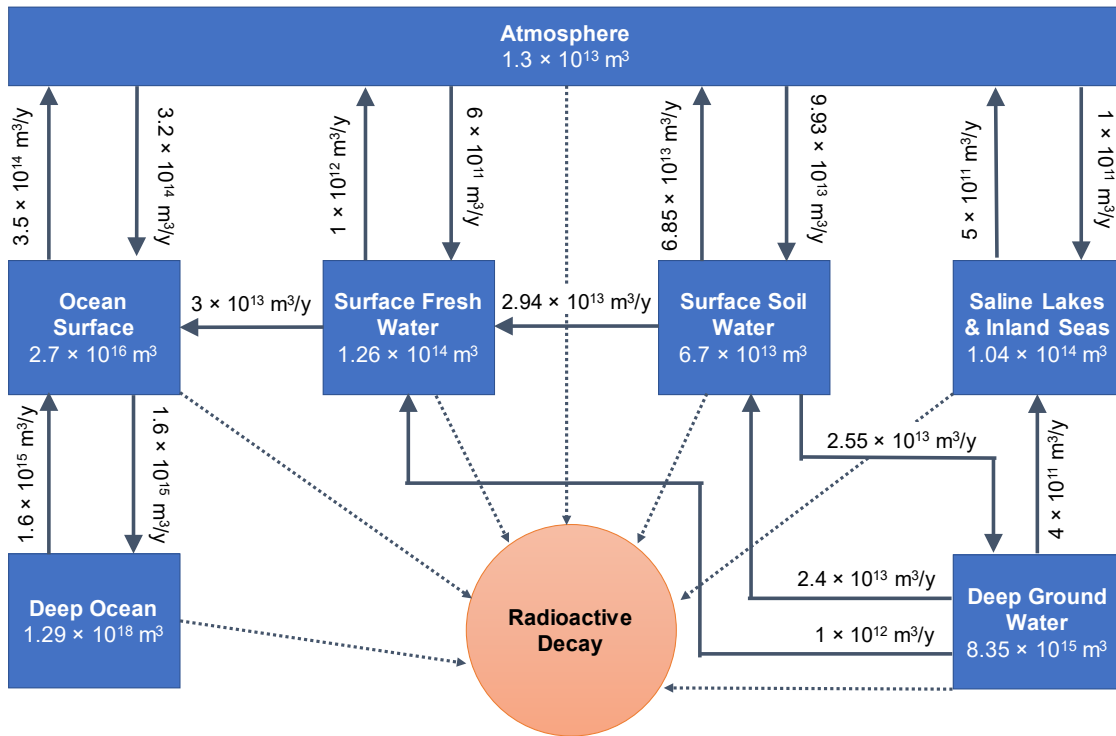

# Results – Effects of Fusion Plant Number and Weapons Testing Comparison

- Assuming 1 g/yr of tritium per 500 MW
  - 500 plants = natural background production
  - 5 plants = 1% of background

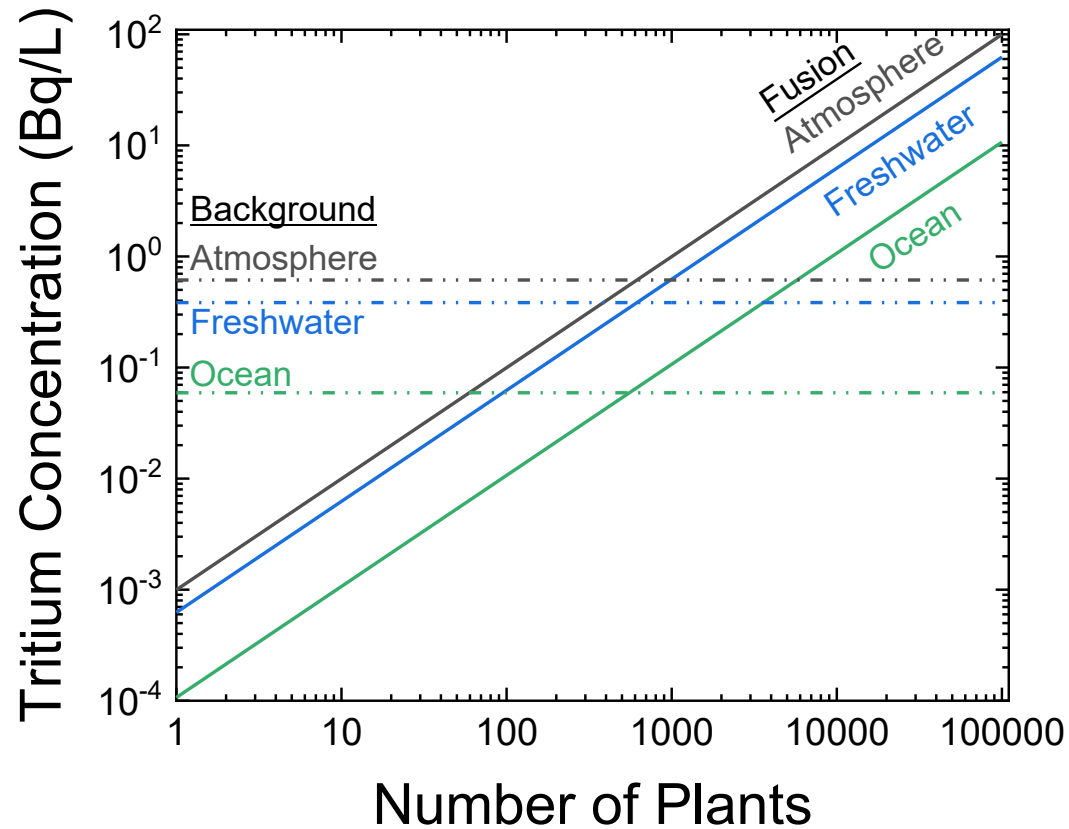

- Atmospheric nuclear weapons testing
  - released significantly more, but not sustained
- Comparison of NWT literature source to fusion
  - NWT tritium different, but interesting comparison....*

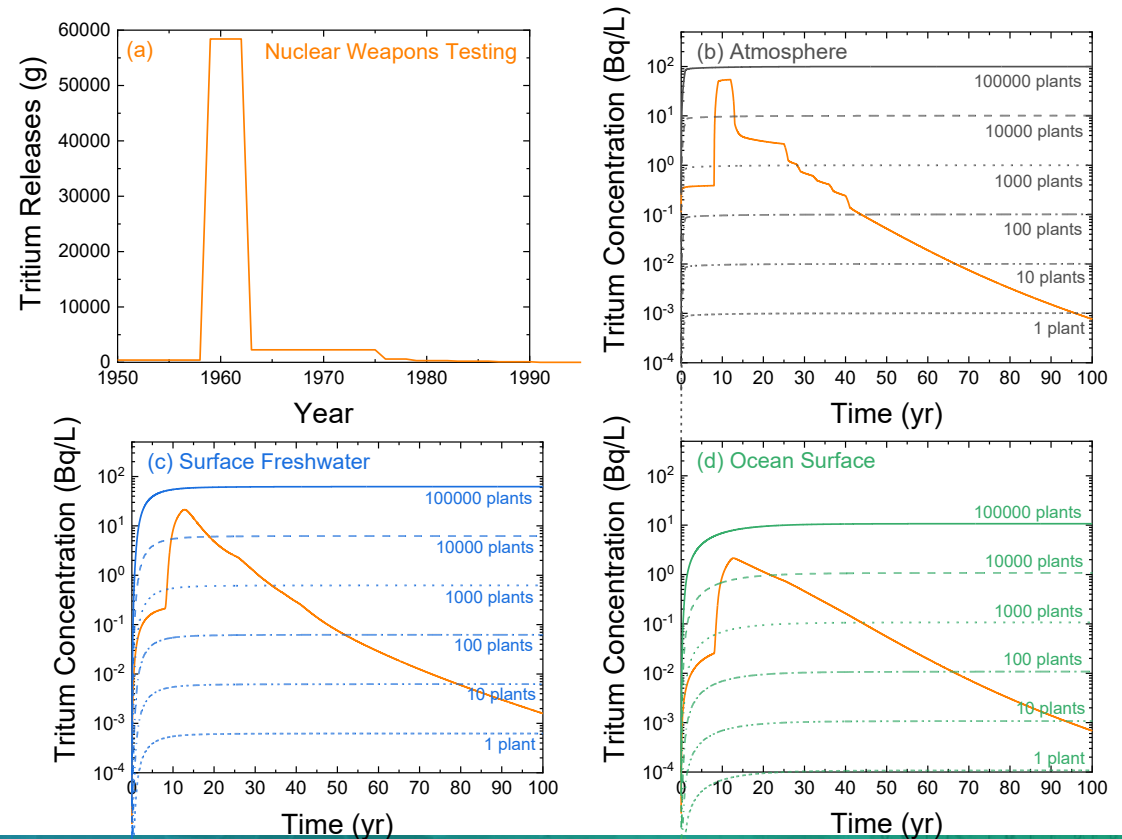

# Discussion – Drinking water standards

- Tritium limits for drinking water vary
  - 76,103 Bq/L in Australia
  - 740 Bq/L in the United States
  - 100 Bq/L in the European Union
- General trend heading for very low levels
  - Not based on health expert guidance
  - Ontario recent push from 7000 Bq/L to 20 Bq/L
    - 7000 Bq/L accepted as safe
  - California EPA has a target of 14.8 Bq/L
- Perception of perceived risk of radiation can rapidly change after significant events
  - e.g., Fukushima
- A large number of fusion power plants may challenge drinking water limits
  - Engage public and health experts; Research effects; Improve technology and operations

Surface Freshwater Release Fraction	Tritium Concentration (Bq/L)						
	Atmosphere	Surface Soil	Deep Ground	Surface Freshwater	Inland Seas	Ocean Surface	Deep Ocean
0	13.15	10.37	0.53	8.23	0.24	1.41	0.0015
0.2	10.80	8.52	0.44	31.52	0.20	1.38	0.0014
0.4	8.45	6.66	0.34	54.80	0.15	1.34	0.0014
0.6	6.10	4.81	0.25	78.09	0.11	1.31	0.0013
0.8	3.75	2.96	0.15	<b>101.38</b>	0.068	1.27	0.0013
1	1.40	1.11	0.057	<b>124.66</b>	0.025	1.23	0.0013



# Summary and Conclusions

---

- The drivers for tritium fuel cycle development are:
  - Safety
  - Cost
  - Tritium inventory
- Challenges are technical but also related to system integration
  - Collaboration is key to address both
- Address bottleneck and critical integration areas first
  - Bottlenecks: Pumps, Direct Internal Recycling, Isotope Separation (and rebalancing)
  - Critical integration areas: Blankets and detritiation
- For tritium processing, there's no real grace period
  - The first of a kind needs to be as good as 10<sup>th</sup> of a kind
    - Inventory and environmental factors are at their highest
- **Acknowledgement**
  - We gratefully acknowledge DOE Office of Science Fusion Energy Sciences Program for supporting our participation
  - We are grateful for research funding from DOE FES, ARPA-E, and NNSA

Thank you!